

LADUNGSSICHERUNG

in Ausbildung und Prüfung
und im echten Leben



Ing. Reinhard Koller
allgemein beeideter und gerichtlich zertifizierter Sachverständiger



Als Mitglied des Fachverbandes vertreten bei

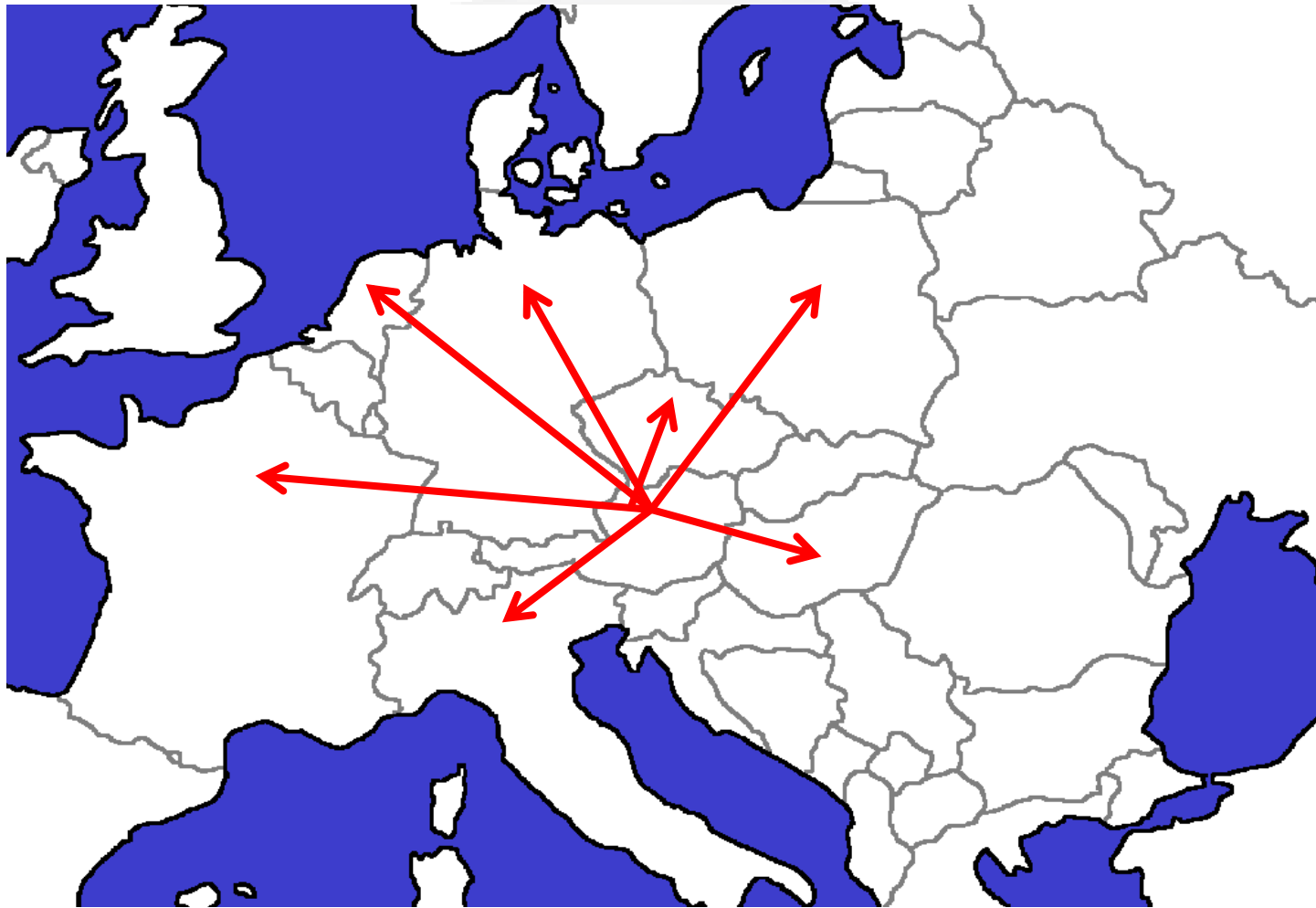

- ✓ über 150 zufriedene Firmenkunden und tausende Schulungsteilnehmer
- ✓ Neutrale Beratung OHNE Produktverkauf
- ✓ Unterwegs als Berater seit 2002 – Cargo safetytec seit 2009
- ✓ VDI Ausbildner; Zivil- und Gerichtssachverständige
- ✓ Mitglied bei internationalen Fachverbänden und Vereinen z.B. EUMOS; KLSK; VDI

Erfahrungswerte: Praxis

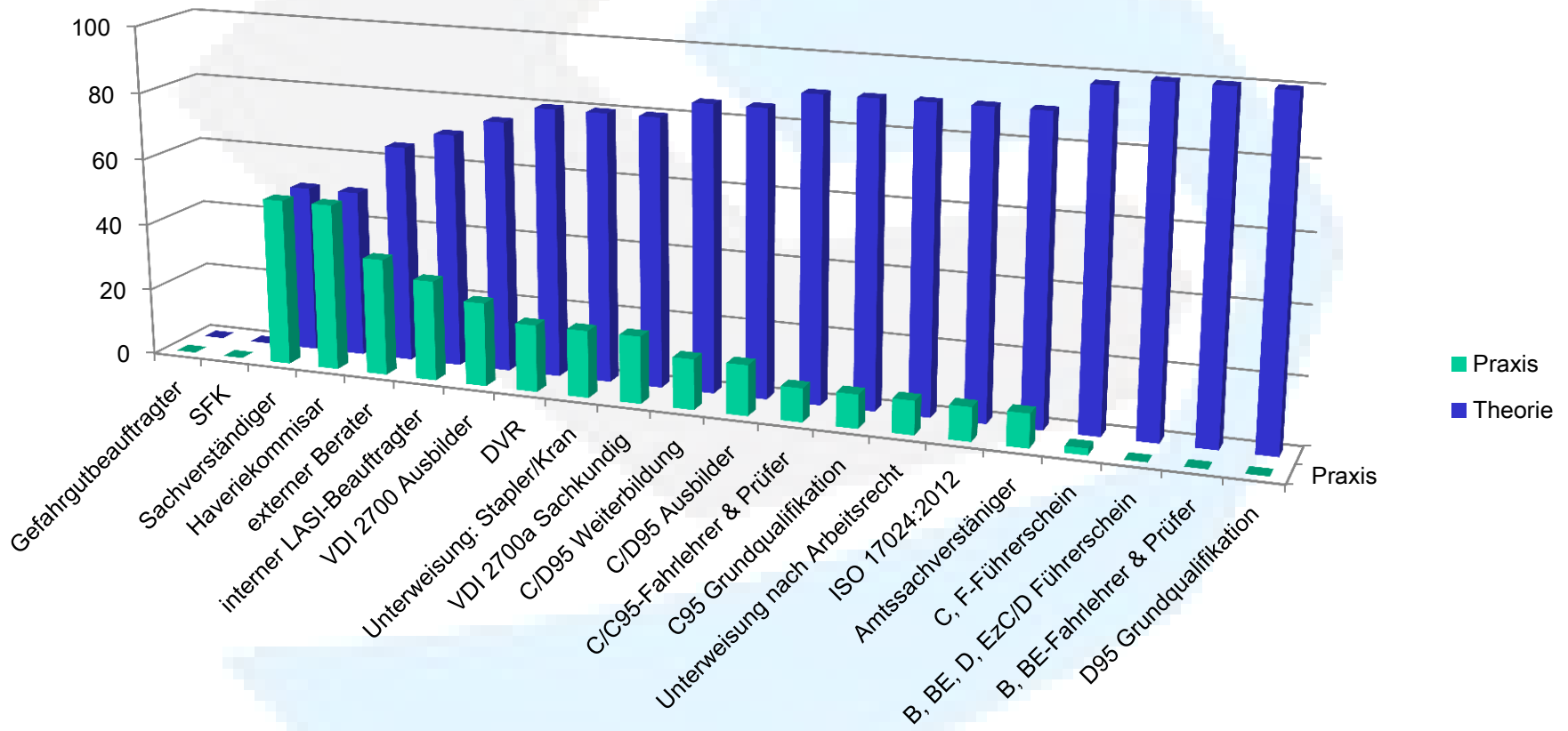

Alltag in Österreich





Verantwortung - Gesetze

Lenker



StVO § 20, § 61, § 58

STVO

KFG § 101, § 102

KFG 101

KFG 102

FSG, ADR

FSG

ASchG, KHVG, DHG

Belader



KFG § 101 1a

KFG 101

AÖTB, CMR, ADR, KHVG

CMR

ASchG, VbVG

VbVG

**Zulassungsbesitzer
(Mieter)**

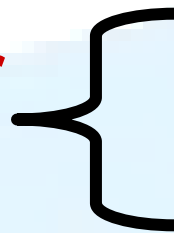

KFG § 101, § 103

KFG 103

ASchG, VbVG, ADR

AÖTB, KHVG, AKKB



Strafsätze

Öffentliches Recht

StVO	max. €	726,--
KFG	max. €	5.000,--
ADR	max. €	50.000,--
VbVG	max. €	1.800.000,--

Privatrecht ??

NO LIMIT!

Verlorene Dämmwolle - 4 Tote



§80,81,88 StGB

Entschuldbare Fehlleistung – Fahrlässig – **Grob Fahrlässig - Vorsatz**

➤ Körperverletzung

FAHRLÄSSIG 3 Monate Freiheit / 180 TS

SCHWER 6 Monate Freiheit / 360 TS

+ besonders gefährl. Verhält. 2 Jahre Freiheit

➤ Tötung

FAHRLÄSSIG 1 Jahr Freiheit

+ besonders gefährl. Verhält. 3 Jahre Freiheit

Kräfte

Abhängigkeit von der Art des Fahrzeugs

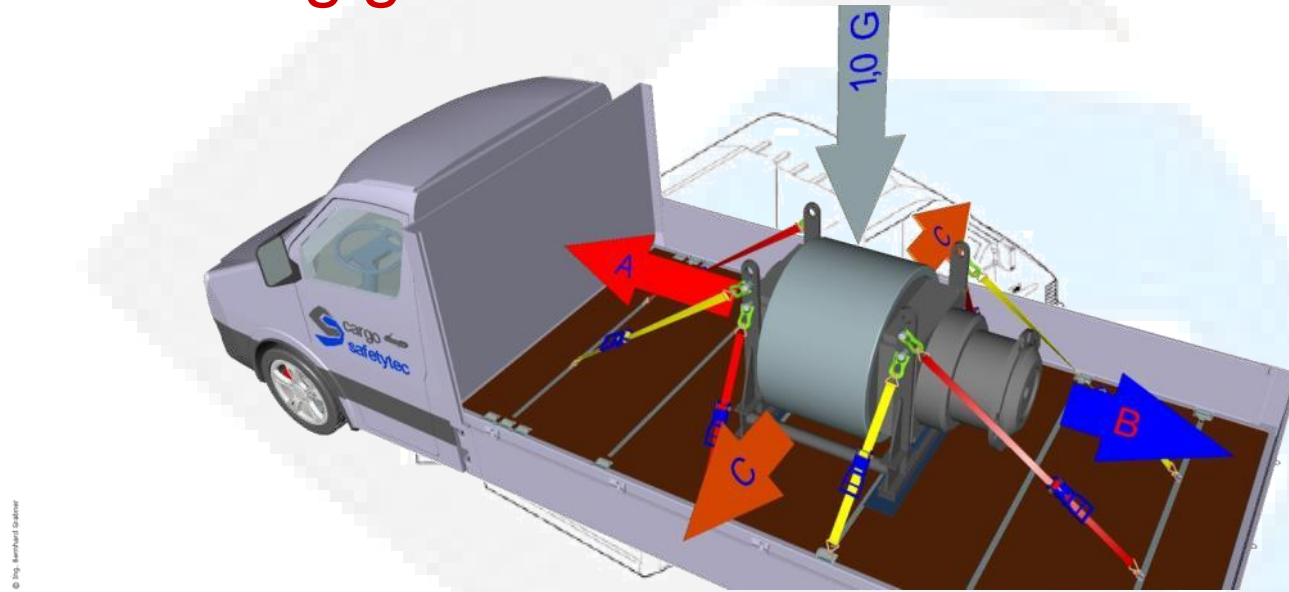

© Dlg, Bernhard Bräuer

Für den üblichen Fahrbetrieb mindestens zu berücksichtigende Massenkräfte:

	Zulässige Gesamtmasse	bis 2,0t	> 2,0t bis 3,5t	über 3,5t
A	Massenkräfte in Fahrtrichtung	$0,9 \times F_G$	$0,8 \times F_G$	$0,8 \times F_G$
B	Massenkräfte entgegen der Fahrtrichtung	$0,5 \times F_G$	$0,5 \times F_G$	$0,5 \times F_G$
C	Massenkräfte in Querrichtung	$0,7 \times F_G$	$0,6 \times F_G$	$0,5 \times F_G$

Lastverteilung ?



Formschluss

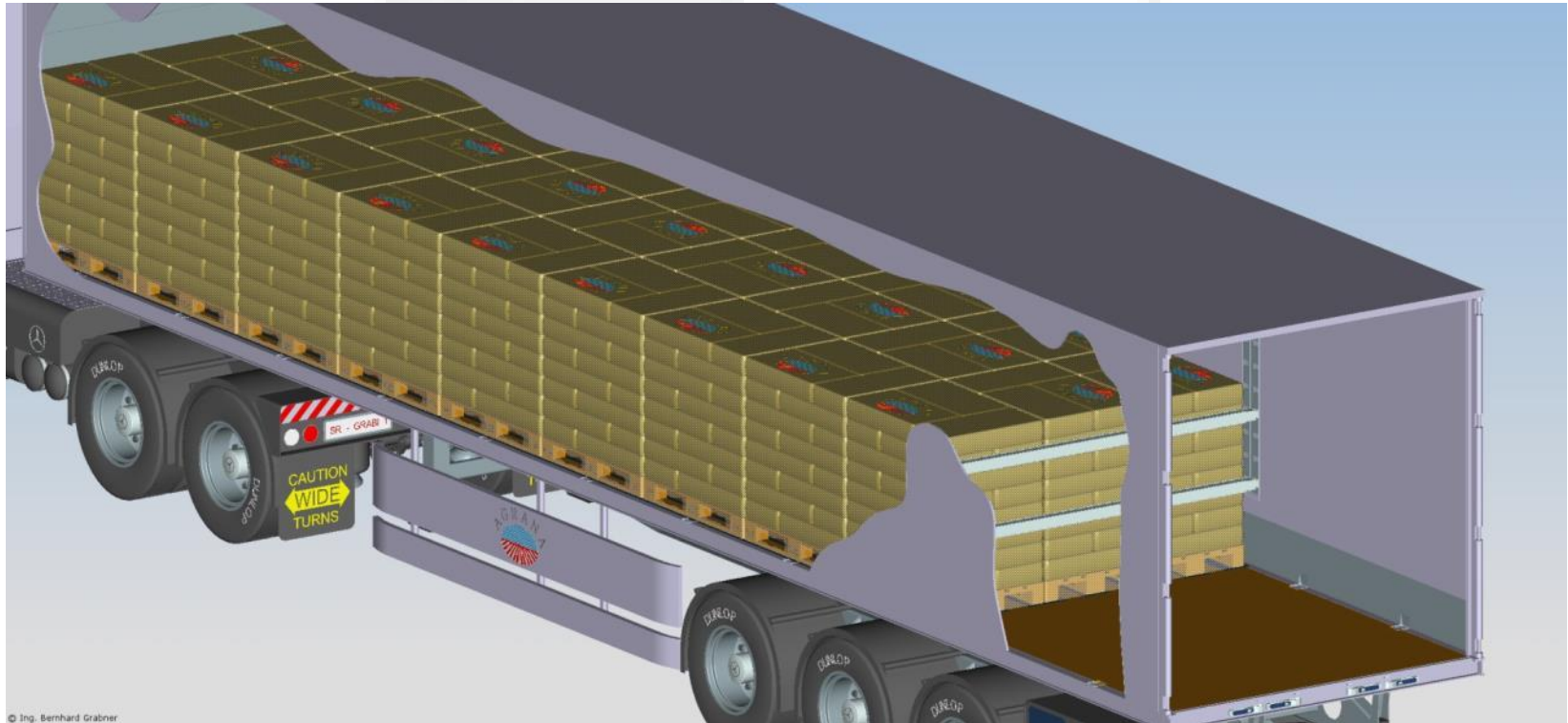

© Ing. Bernhard Grabner

Formschluss

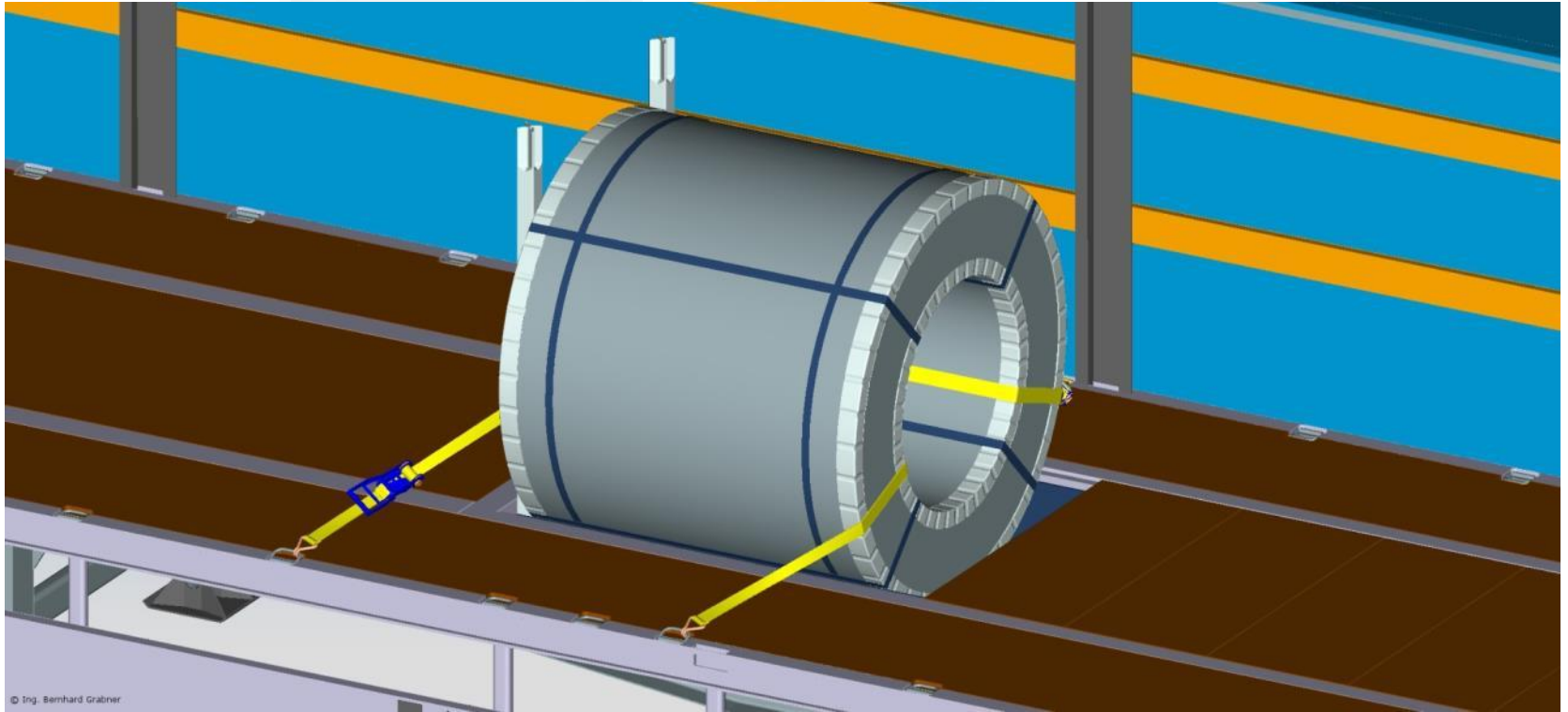

Formschluss

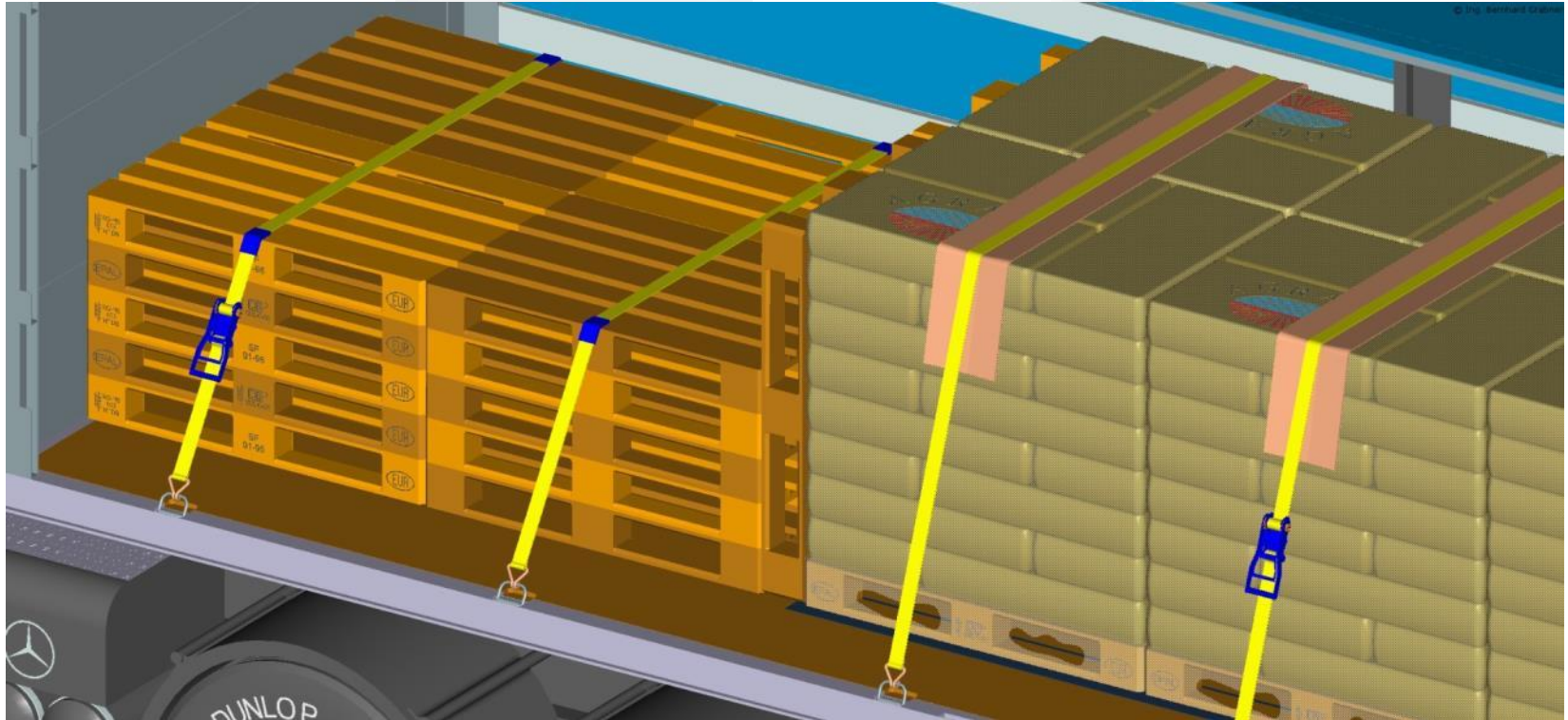

Formschluss



Formschluss

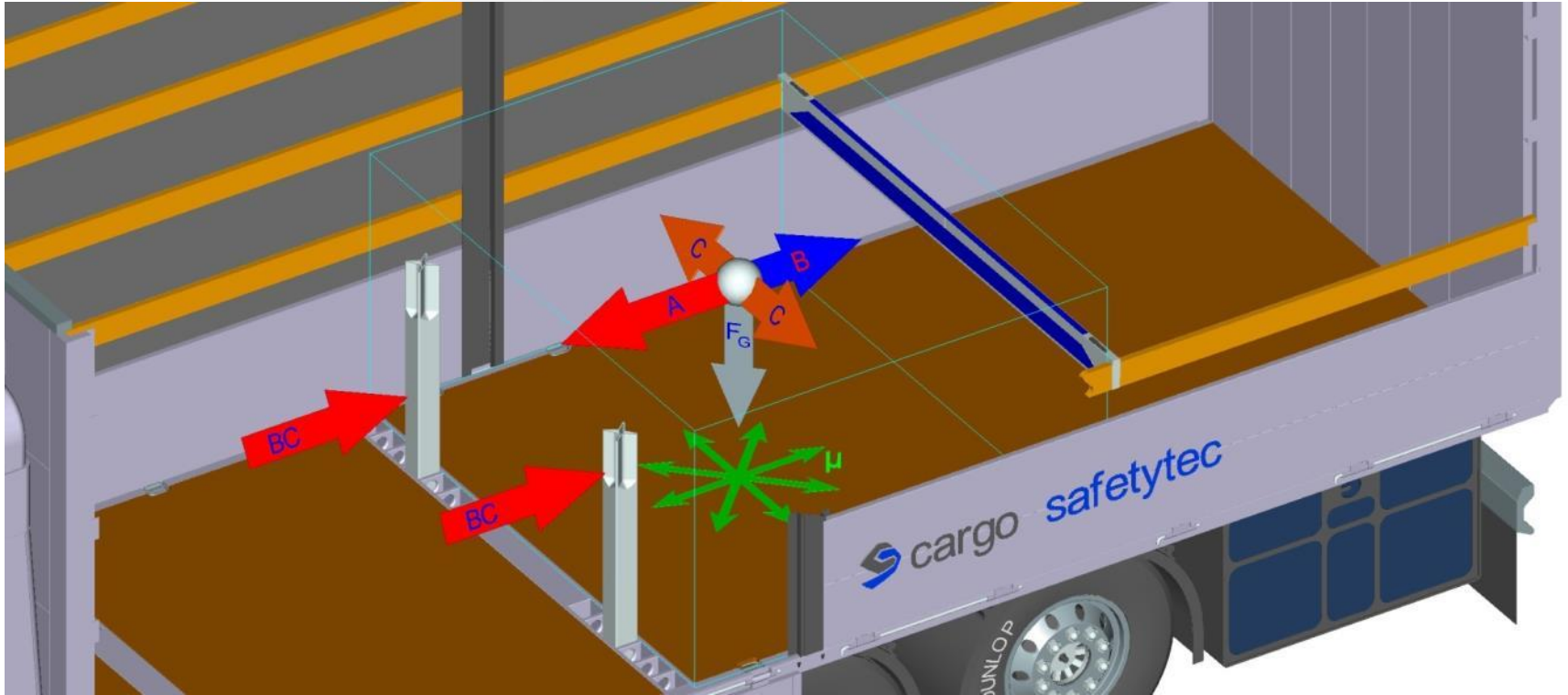

© Ing. Bernhard Grabner

Kennzeichnung

➤ Bisherige K.



➤ Jetzige K.

- Festende

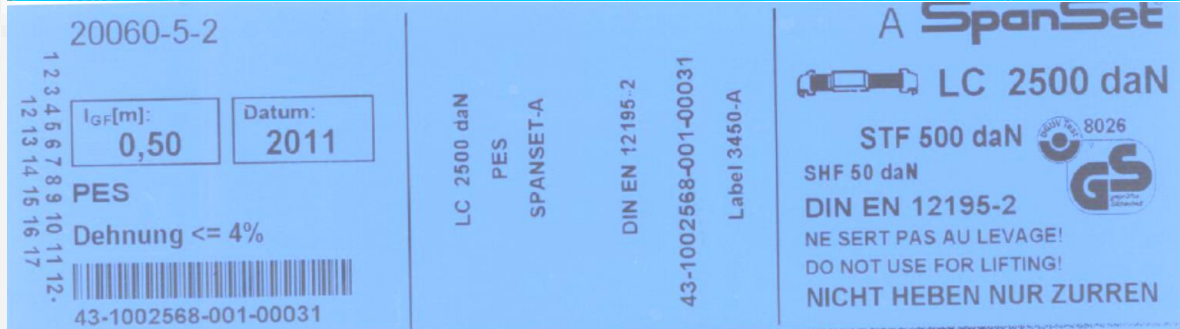

- Losende

• (kein STF)

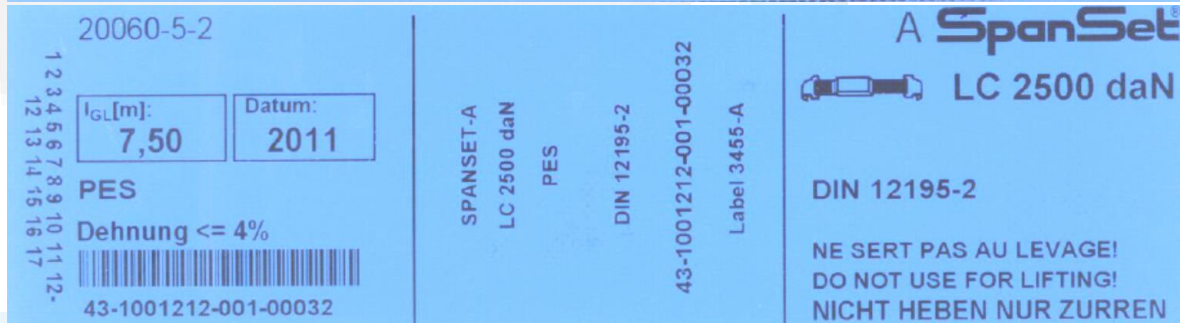

- 25mm Gurt

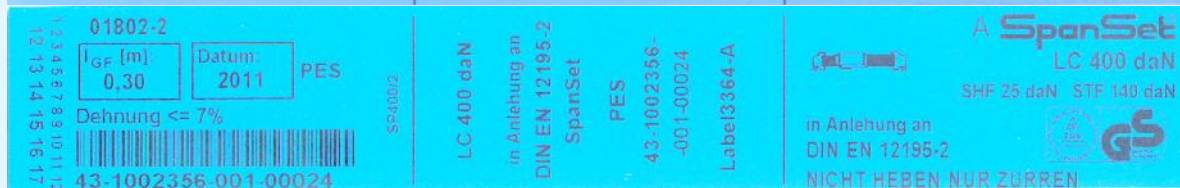

Niederzurren

© Ing. Bernhard Grabner

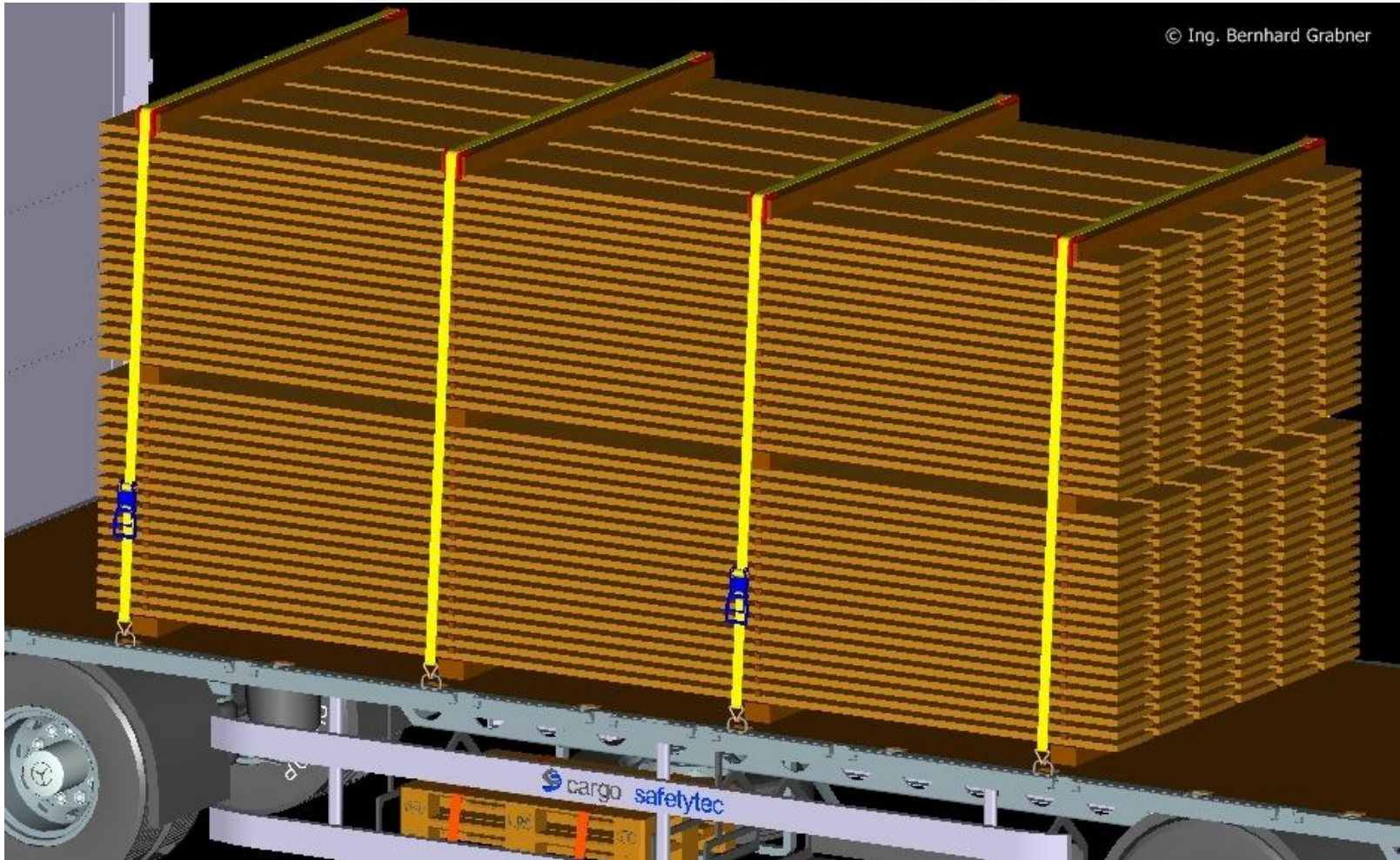

Niederzurren



Niederzurren

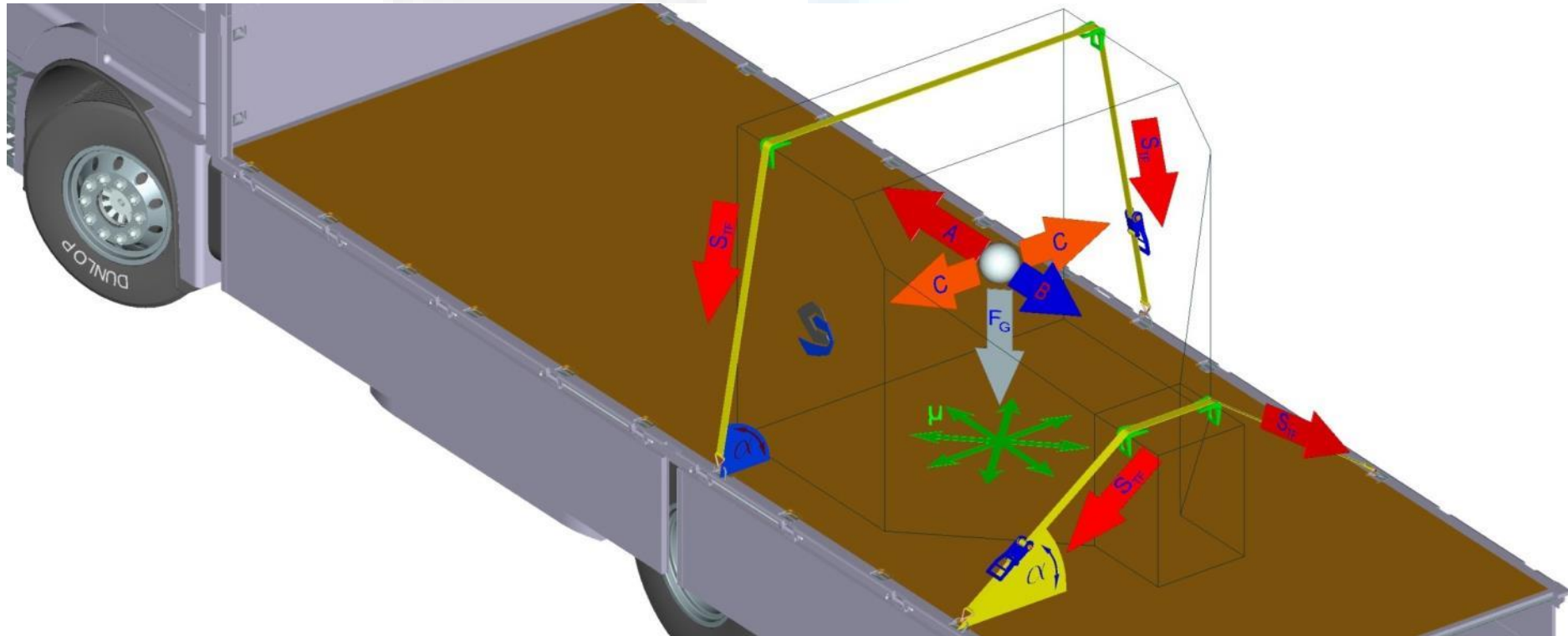

Diagonalzurren

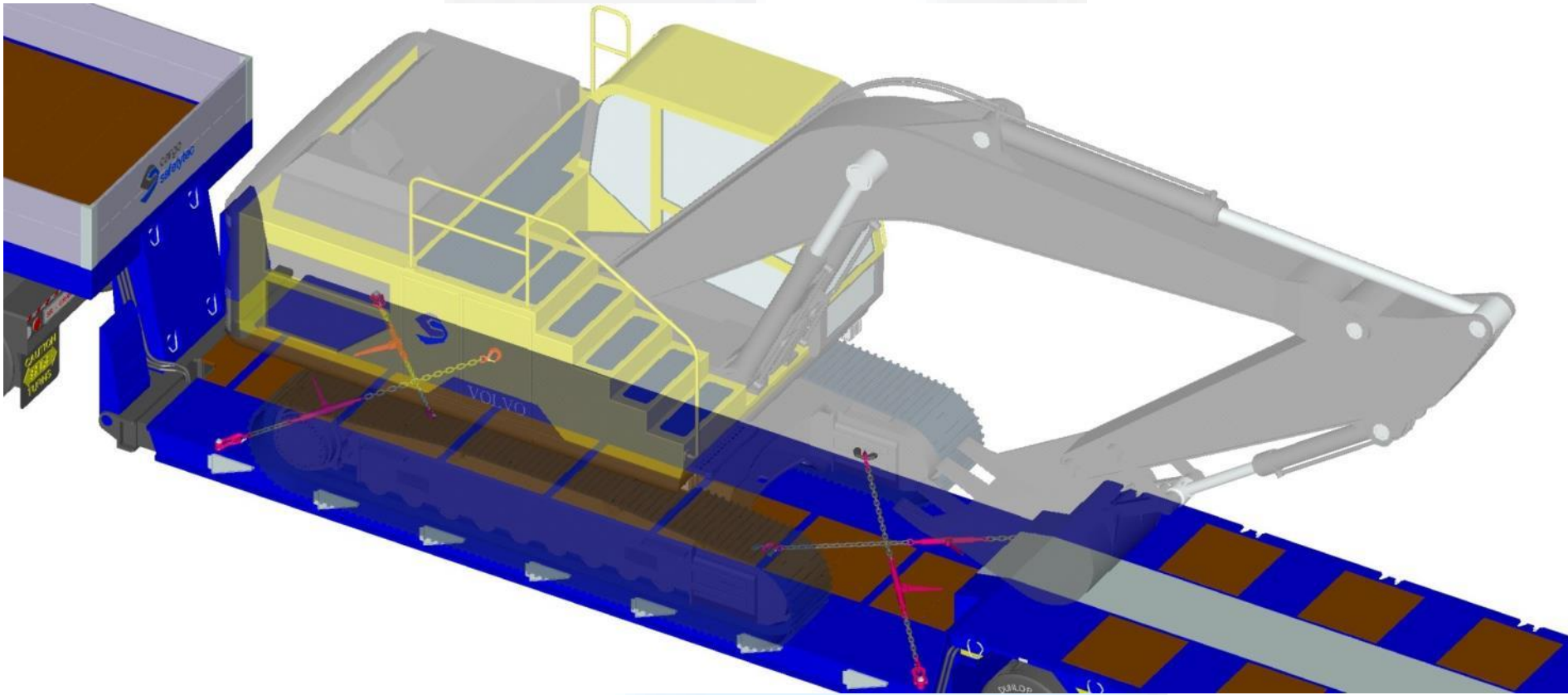

Diagonalzurren



© Ing. Bernhard Grabner

Diagonalzurren

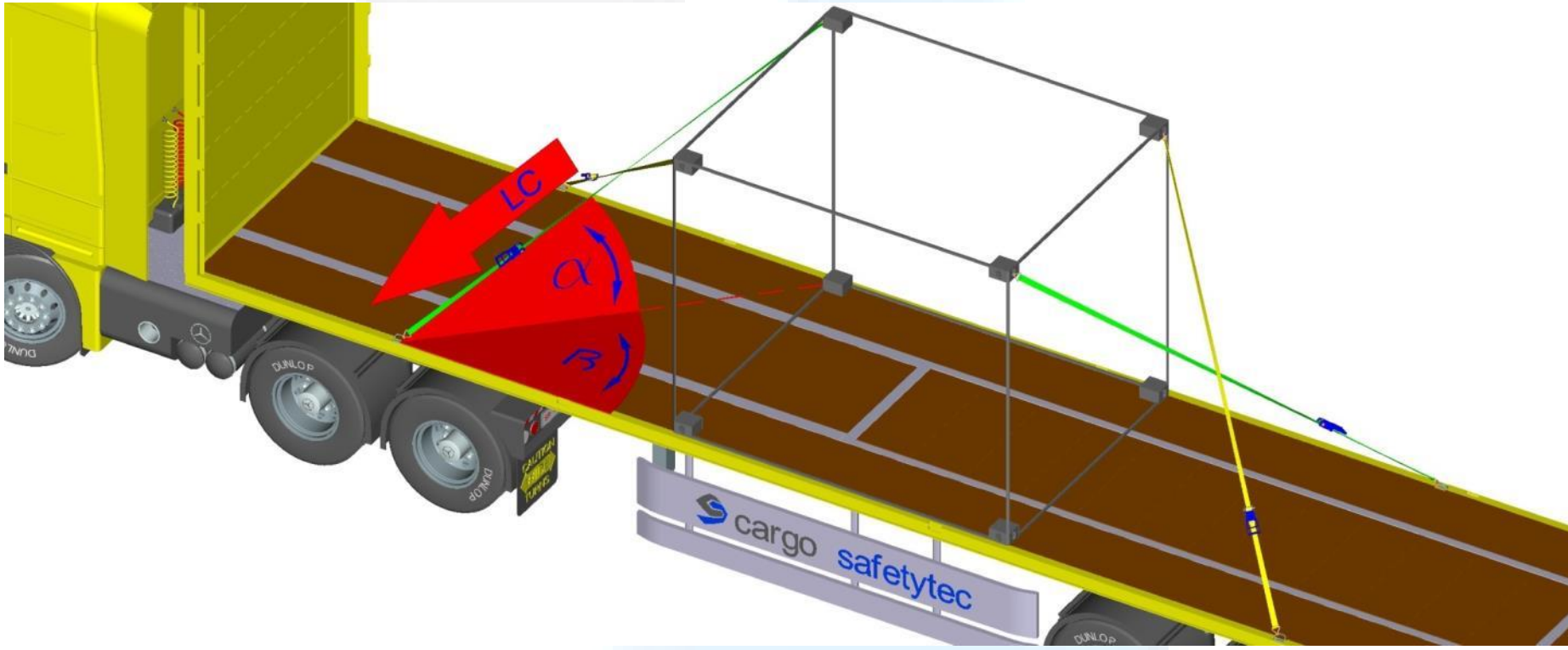

Diagonalzurren

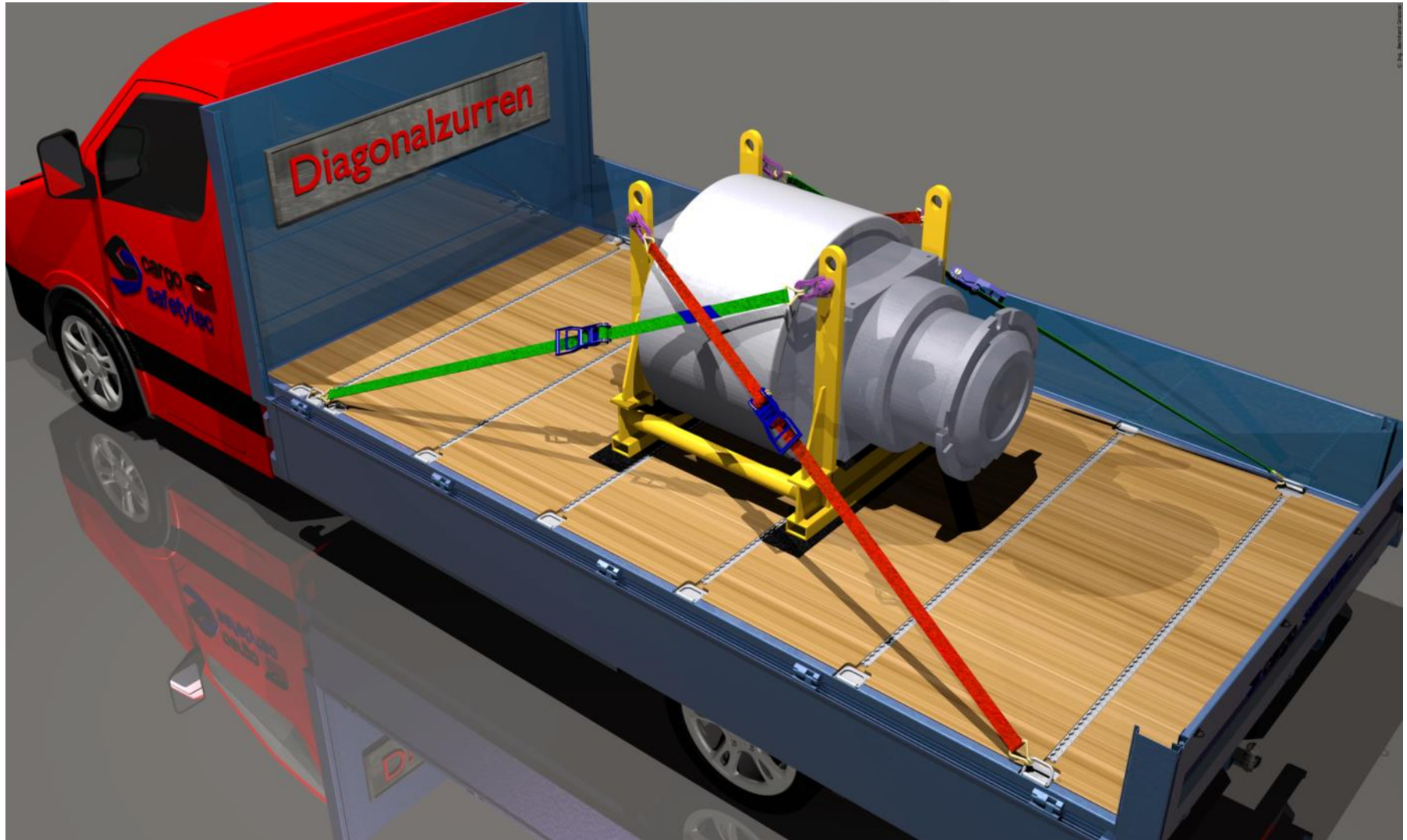

Diagonalzurren

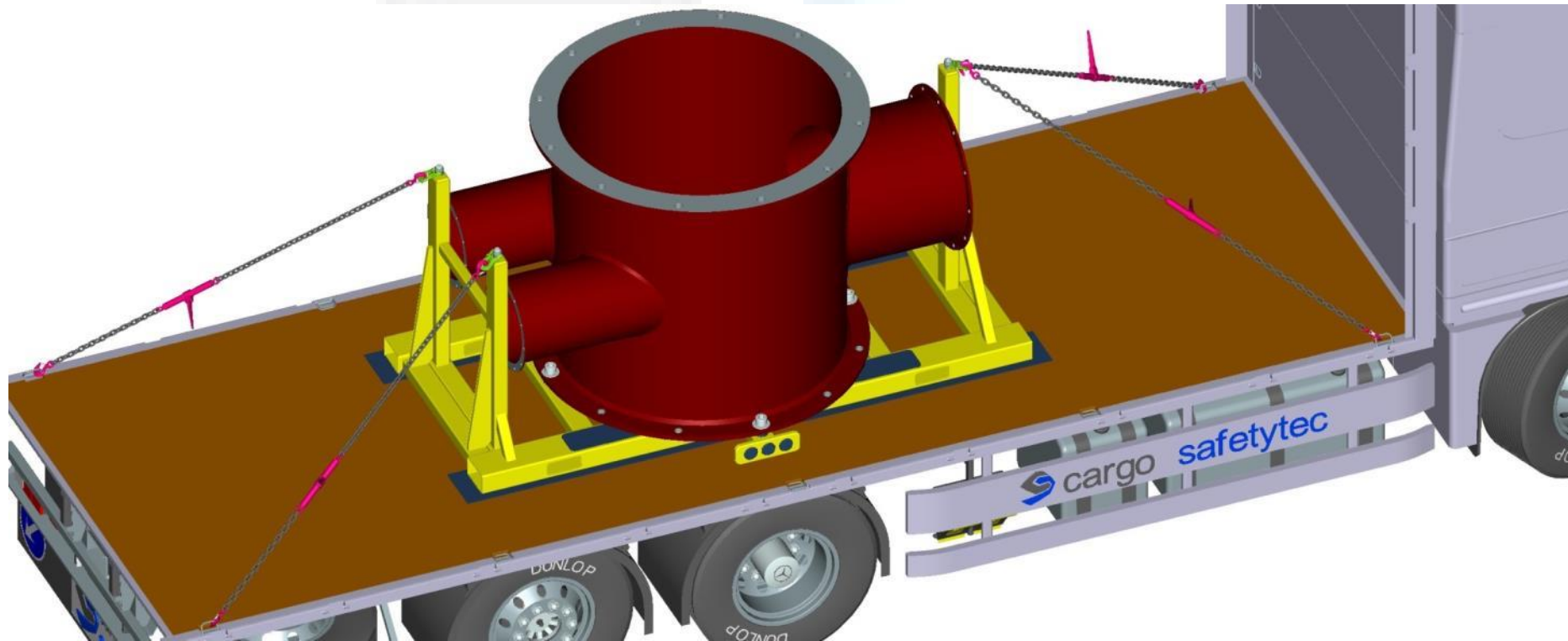

Schrägzurren

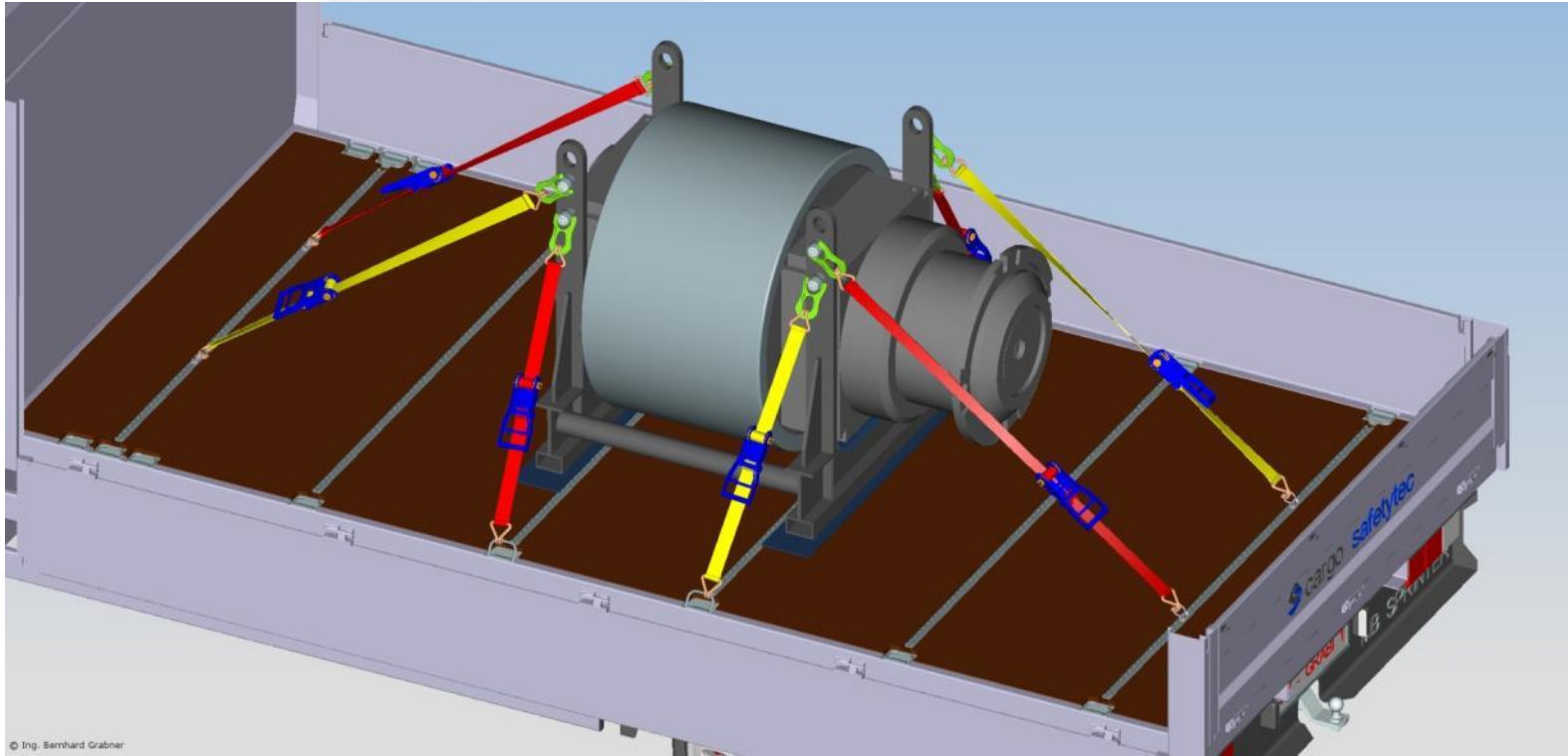

© Ing. Bernhard Grabner

Horizontalzurren

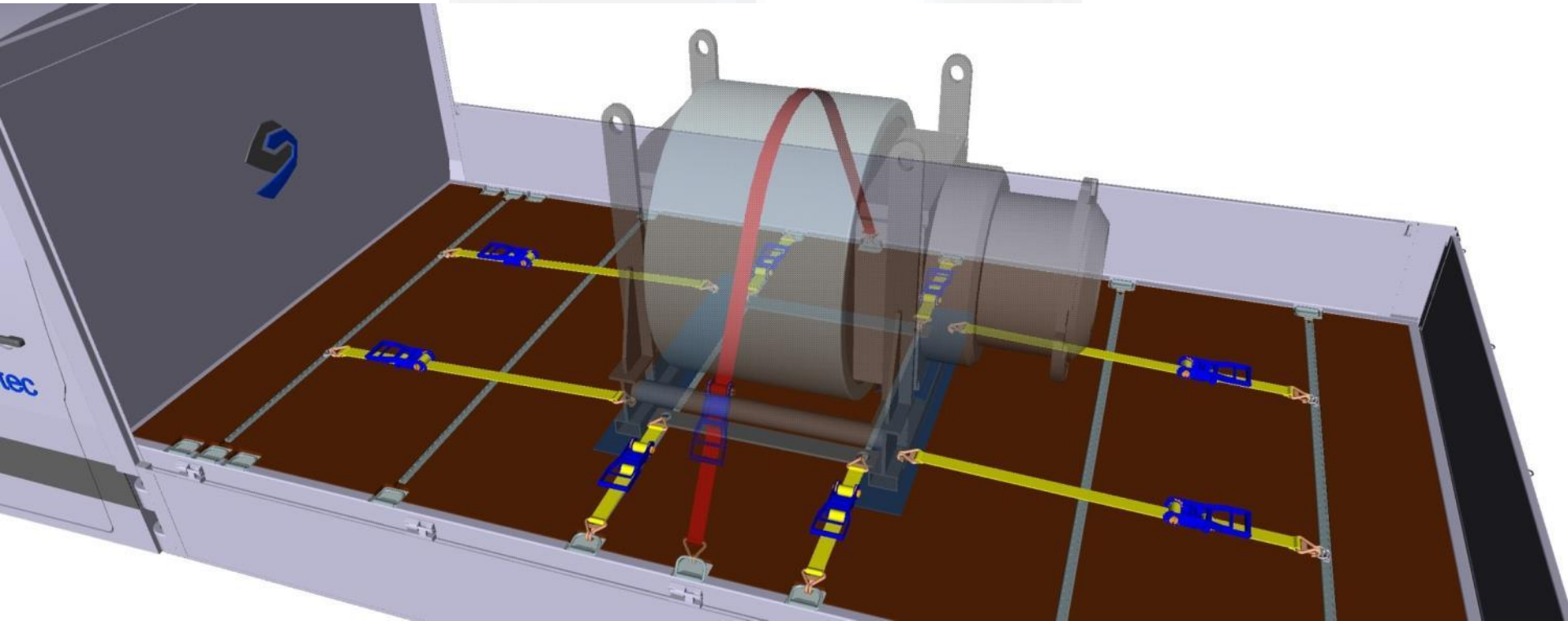

Kopflashing / Kopfschlingenzurren

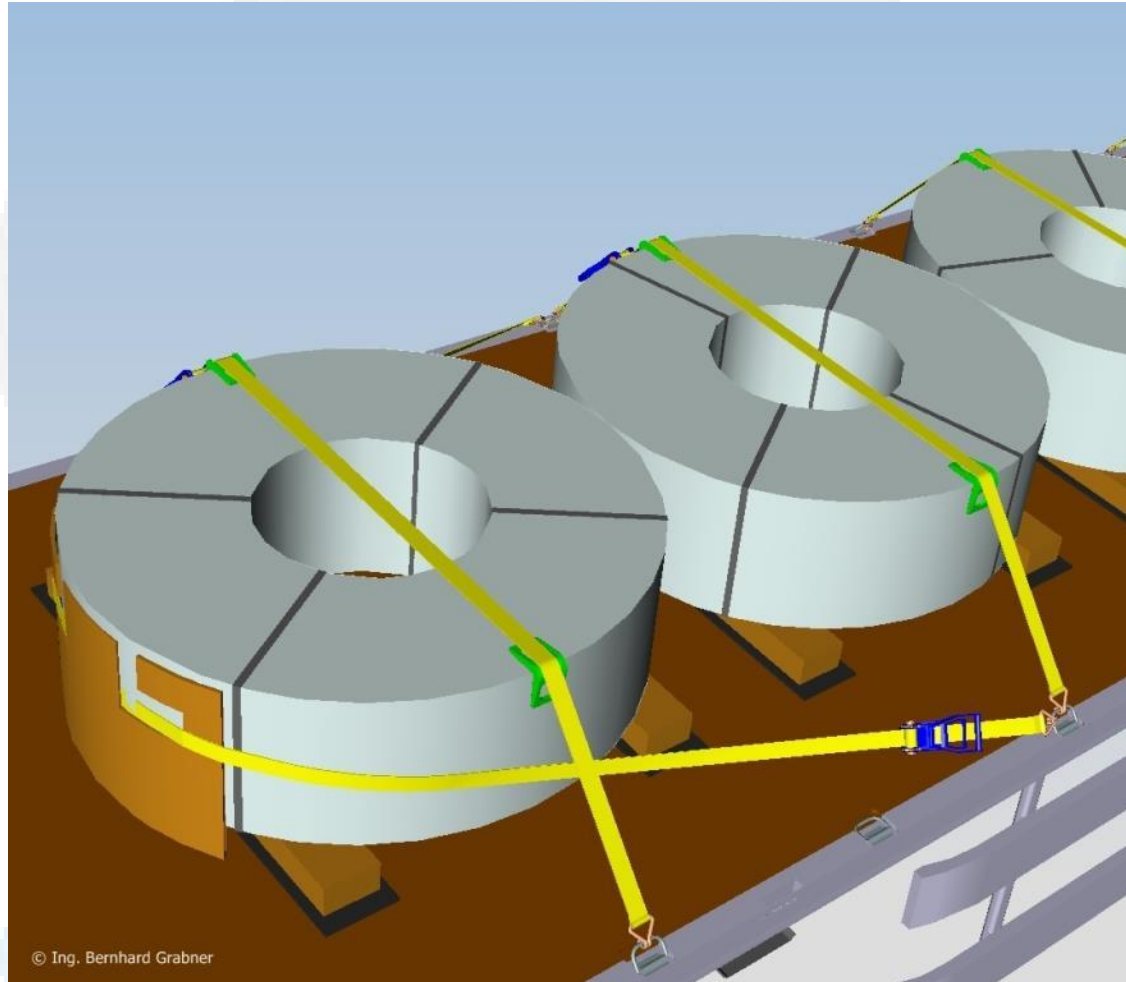

© Ing. Bernhard Grabner

Kopflashing / Kopfschlingenzurren

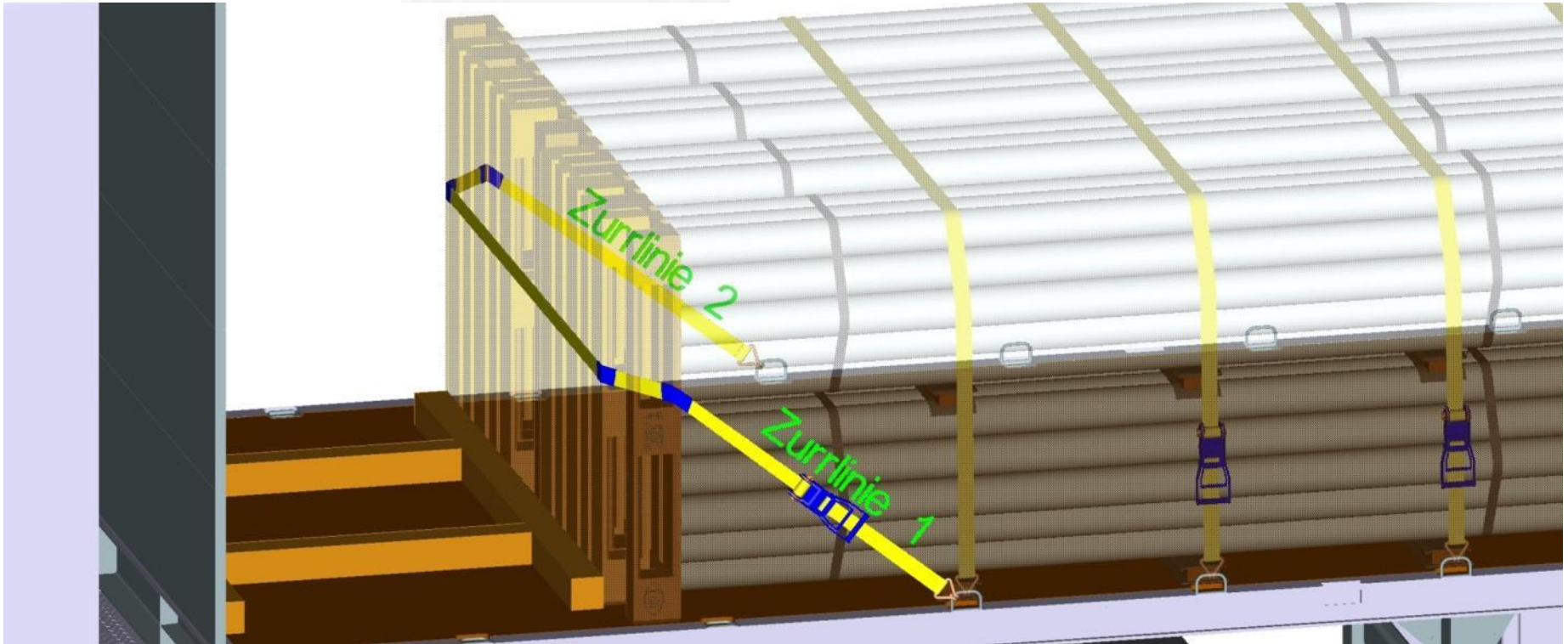

Kopflashing / Kopfschlingenzurren

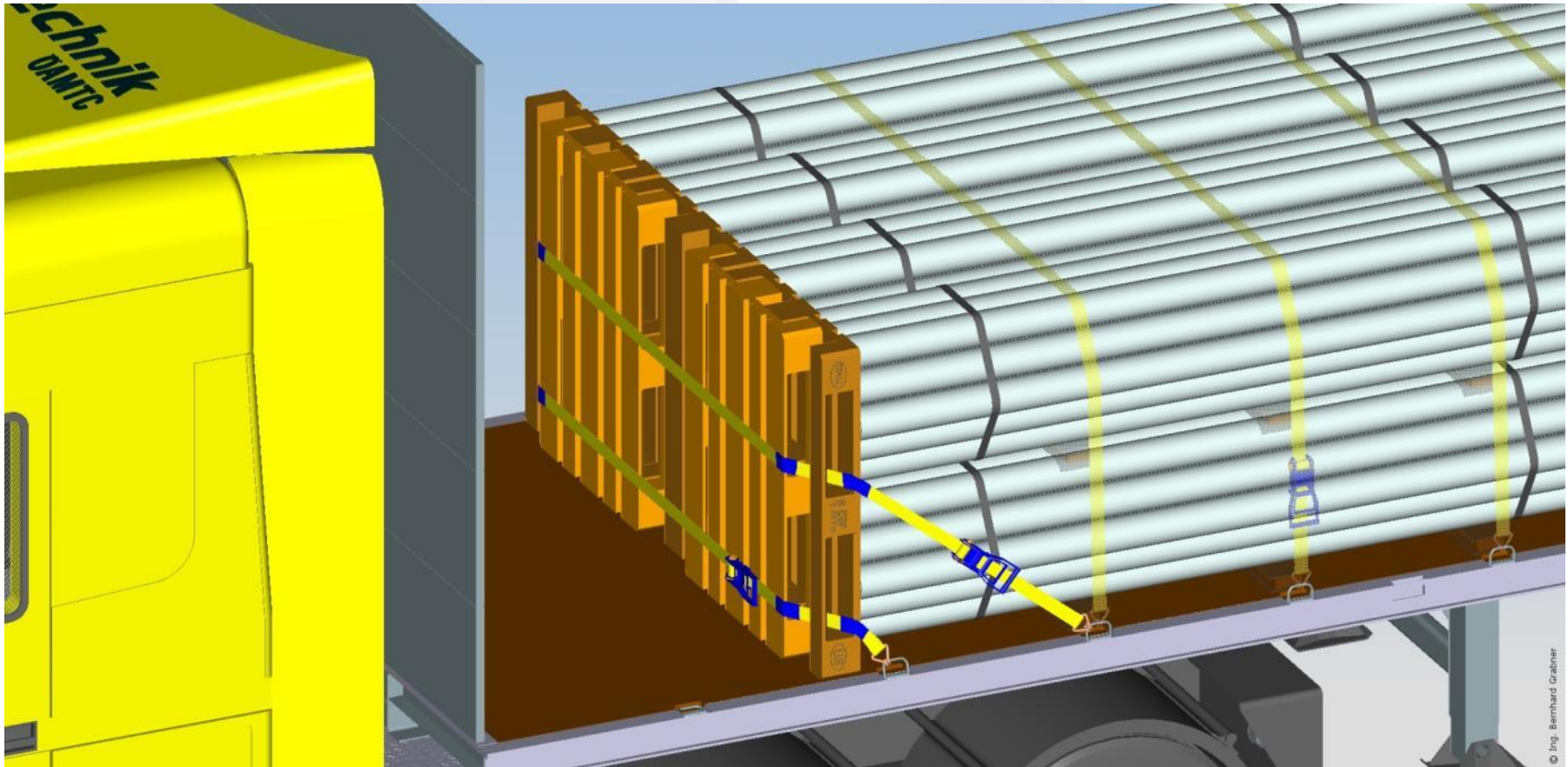

© Ing. Bernhard Grabner

Kopflashing / Kopfschlingenzurren

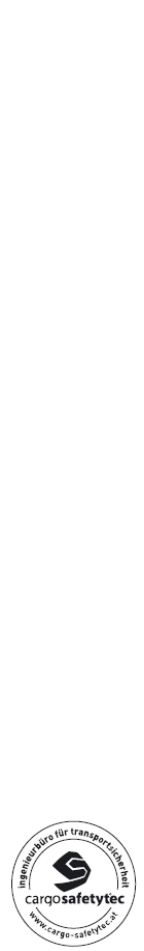
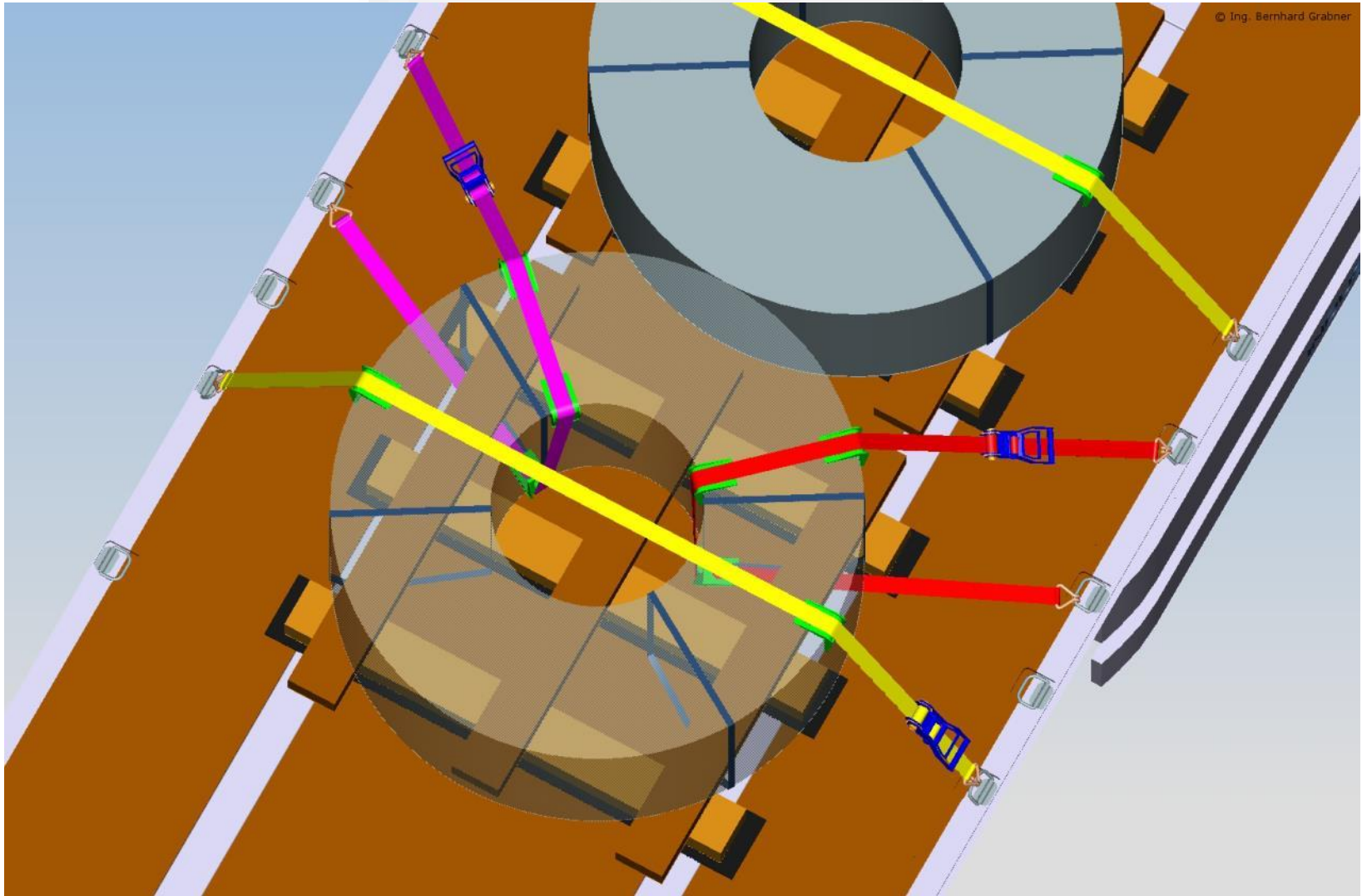

Kopflashing / Kopfschlingenzurren

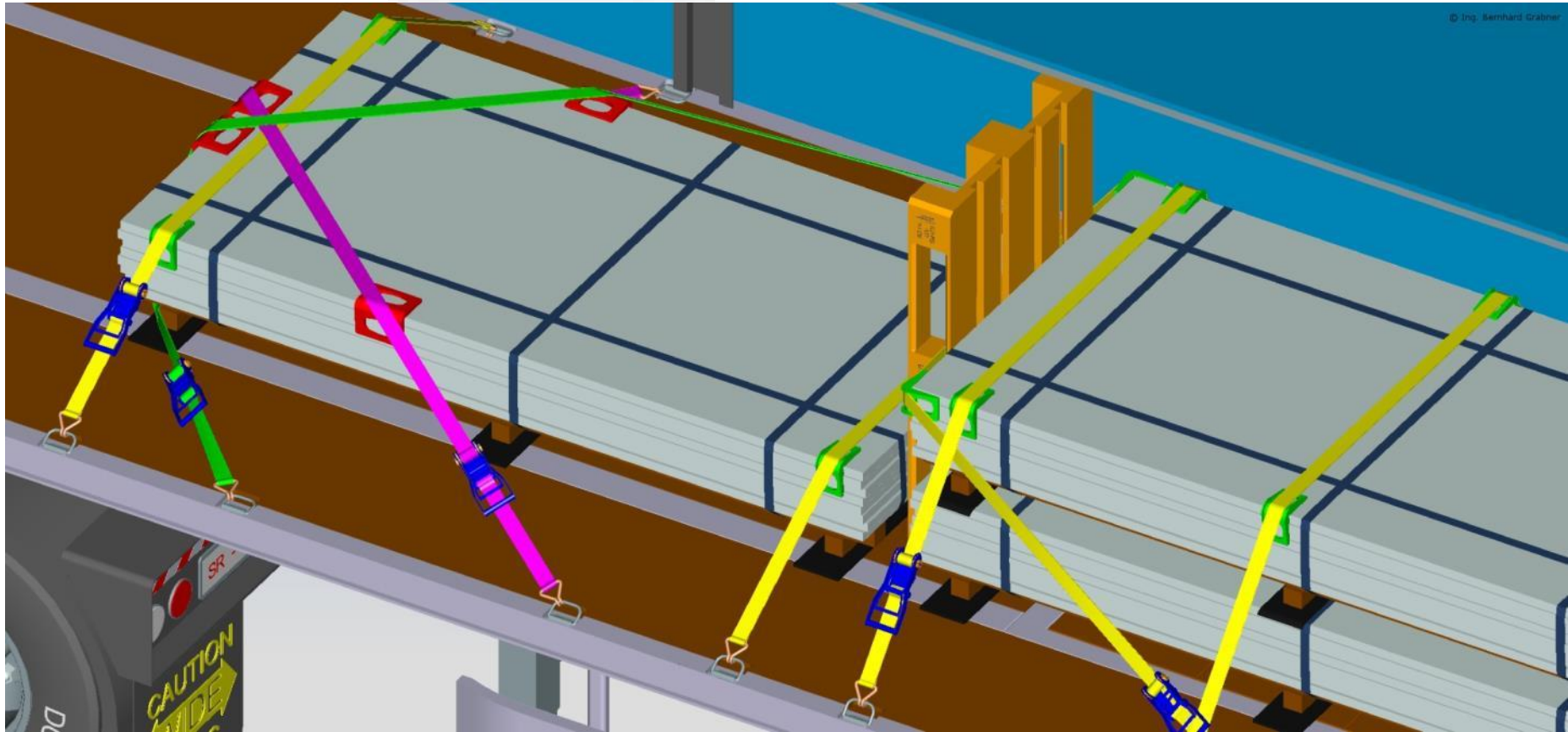

Kopflashing / Kopfschlingenzurren

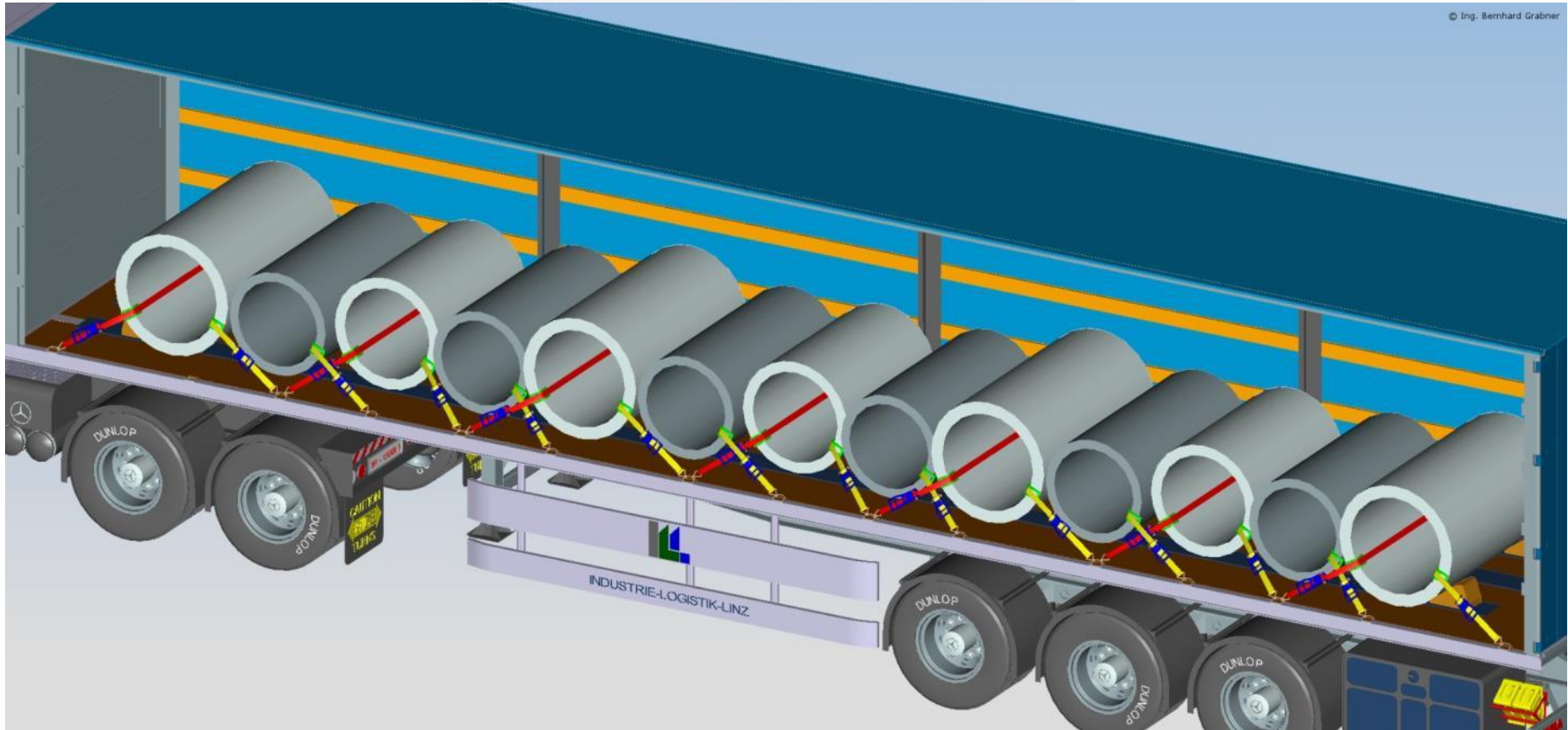

Kopflashing / Kopfschlingenzurren

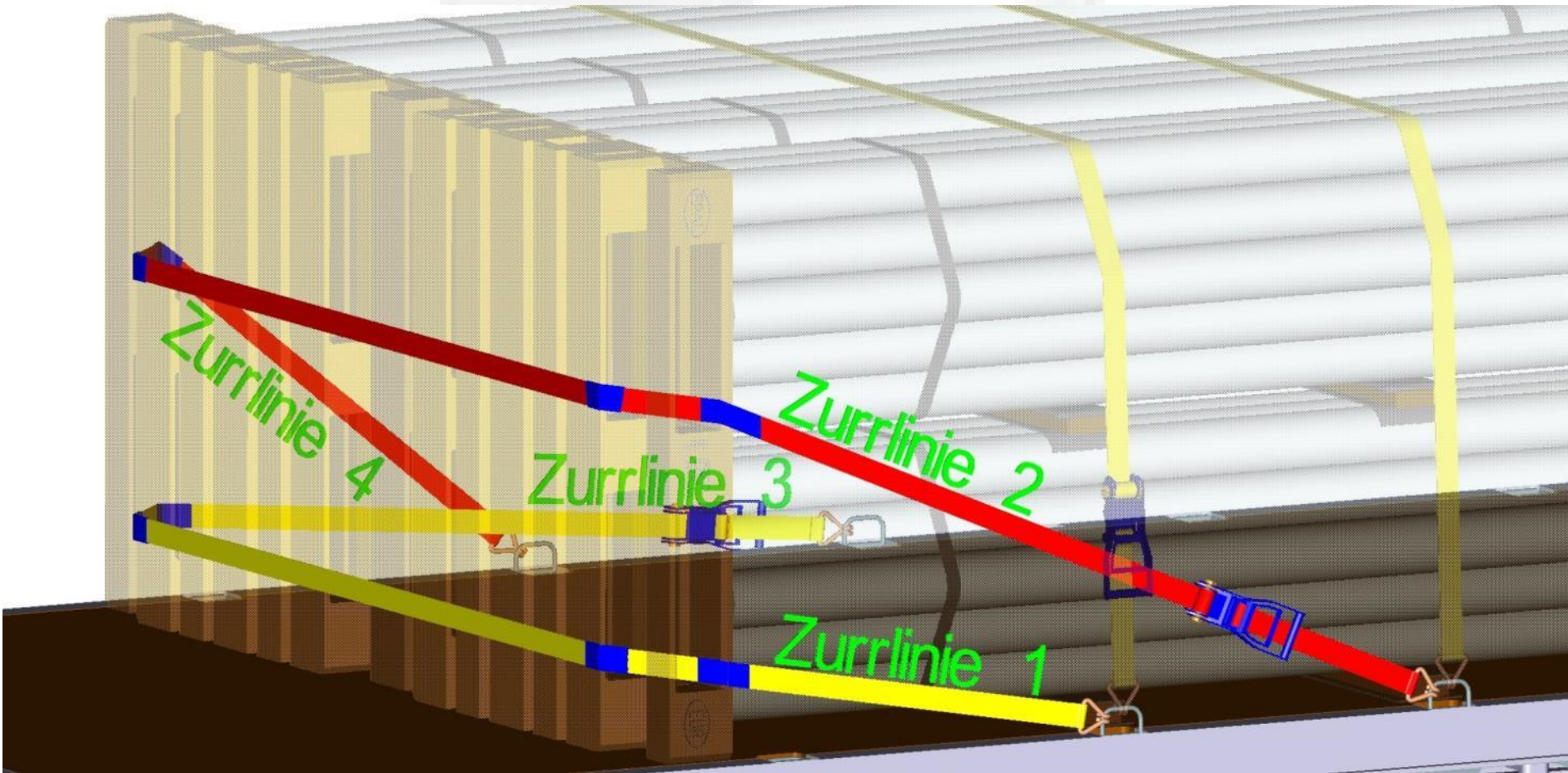

Buchtlashing / Seitenschlingenzurren

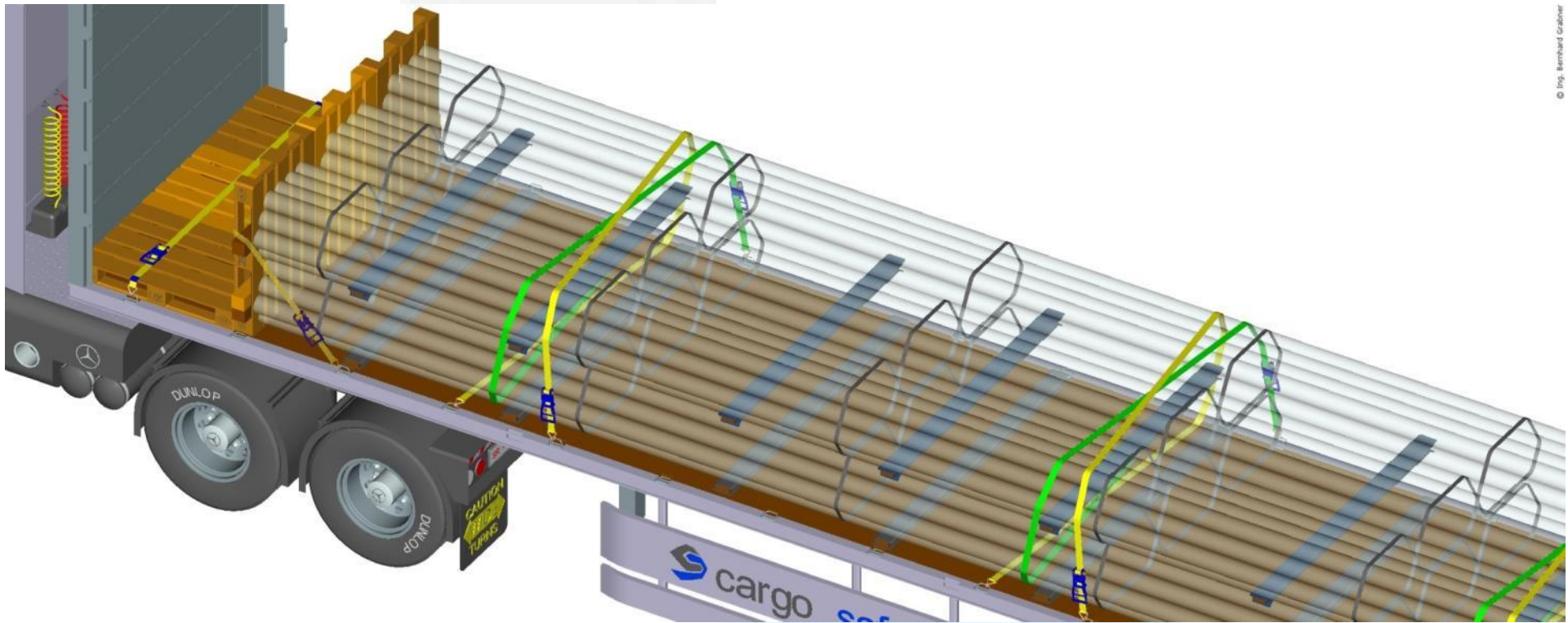

© Dr. Bernhard Grabner

Buchtlashing / Seitenschlingenzurren

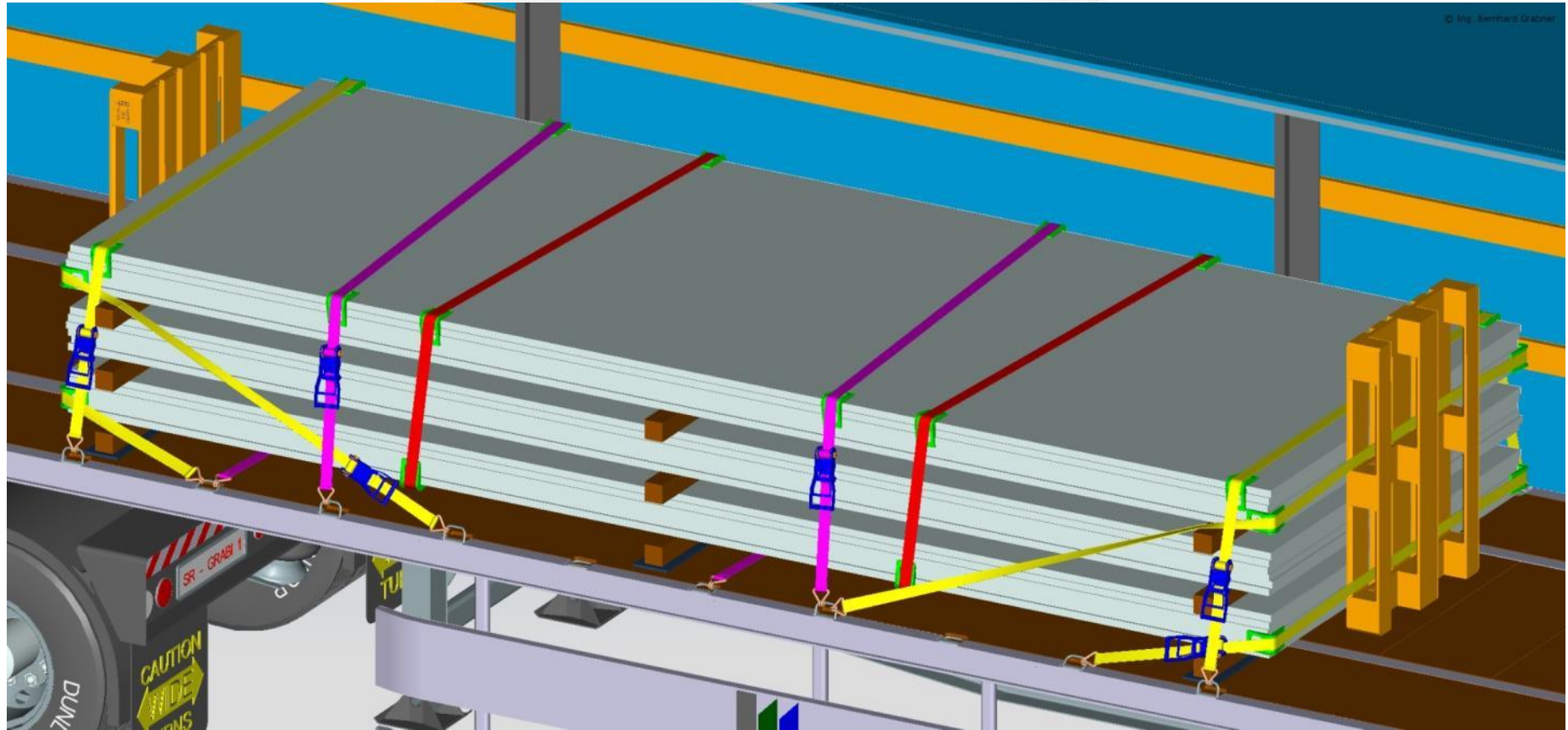

Kombination: Bündeln – Diagonal - Kopflashing

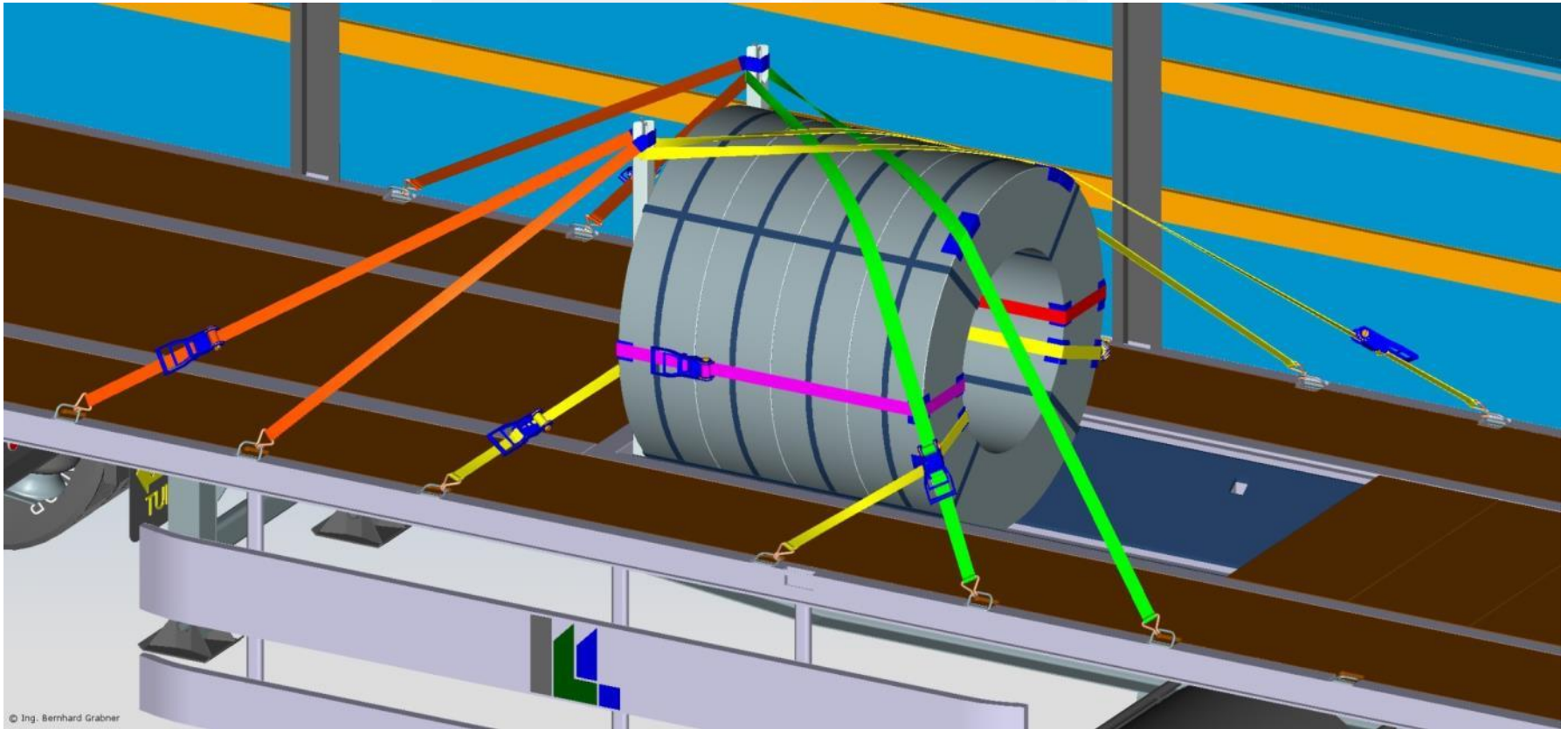



cargo safetytec

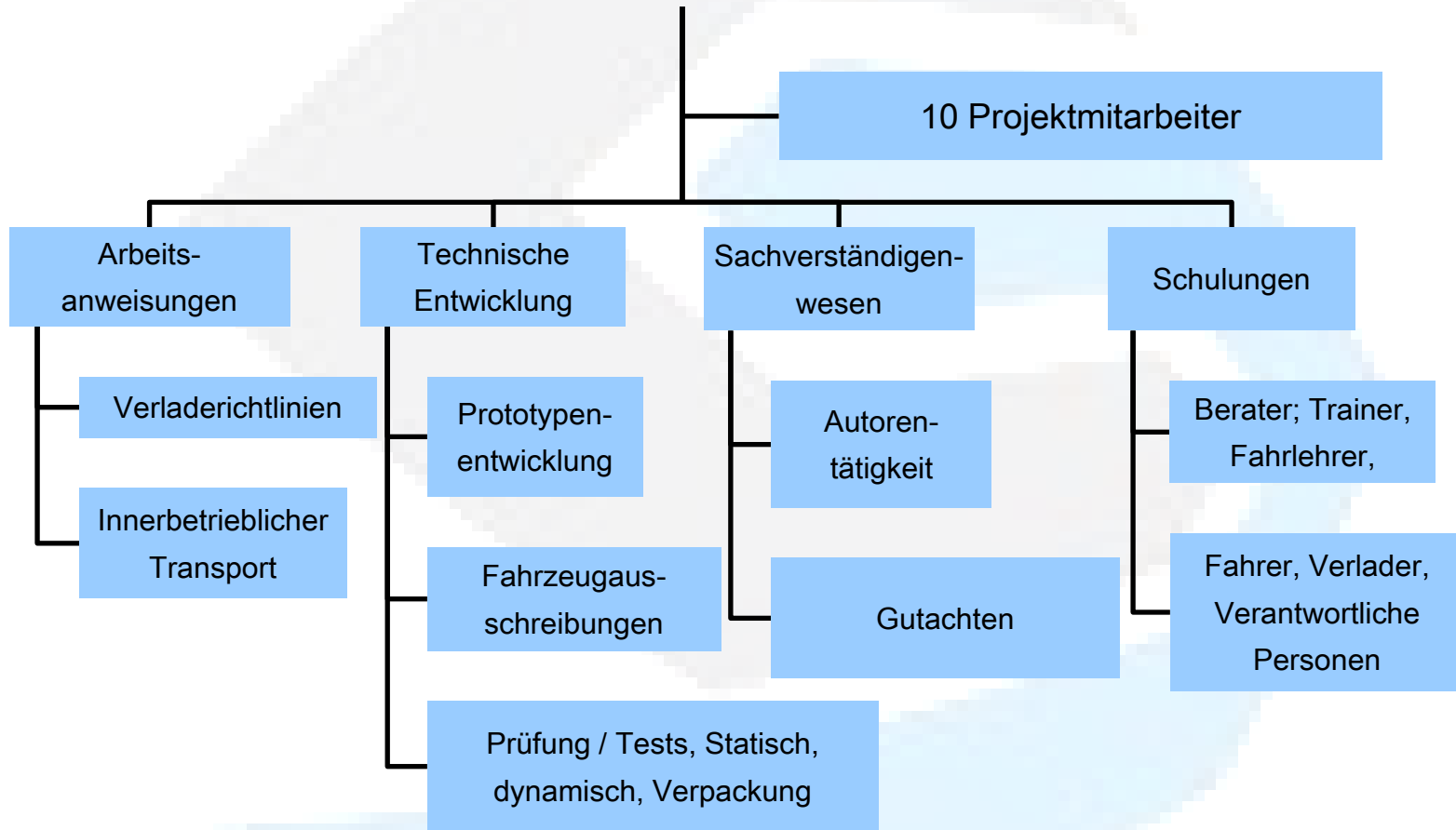

Ing. Reinhard Koller
allgemein beeideter und gerichtlich zertifizierter Sachverständ