

7

Schnitt A-A

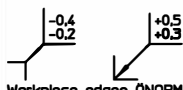
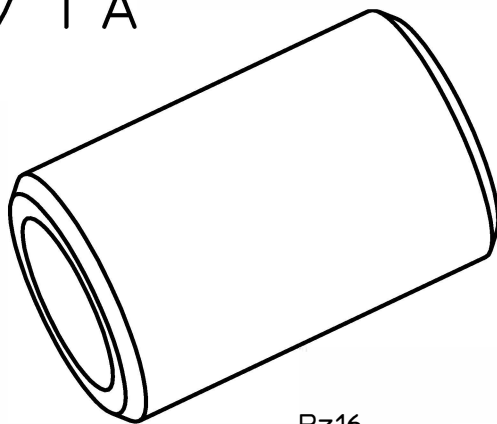
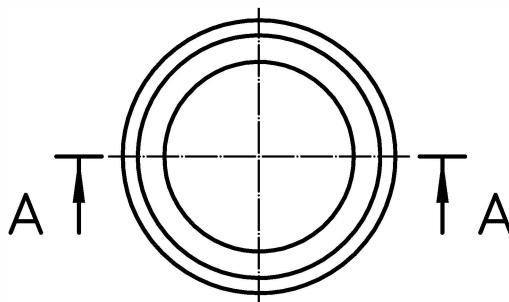
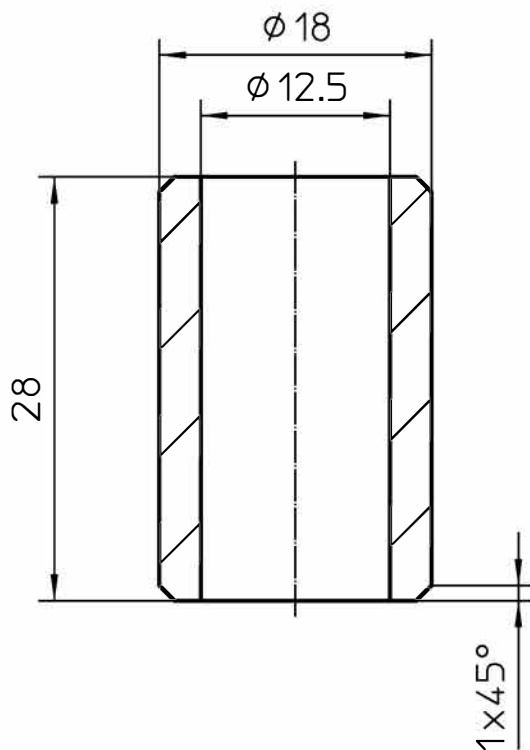

Workpiece edges DIN ISO 13715

Allgemeintoleranzen ISO 22081

lineare Größenmaße: ± 0.1

Winkelgrößenmaße: $\pm 1^\circ$

Rz16



| Menge | Pos.-Nr. | Benennung | Material | Rohmaß | Beschreibung |
|-------|----------|----------------------------------|----------|--------|--------------|
| 3 | 7 | Distanzbuchse $\varnothing 12,5$ | Messing | | |

LEHRLINGSWETTBEWERB

Maßstab

1:1

Schnittwerkzeug



Variante 2



Beruf: M2

Zeichnungs- Nr.: M2-2h_V1.0

Diese Zeichnung ist Eigentum der WIRTSCHAFTSKAMMER - Oberösterreich