

6

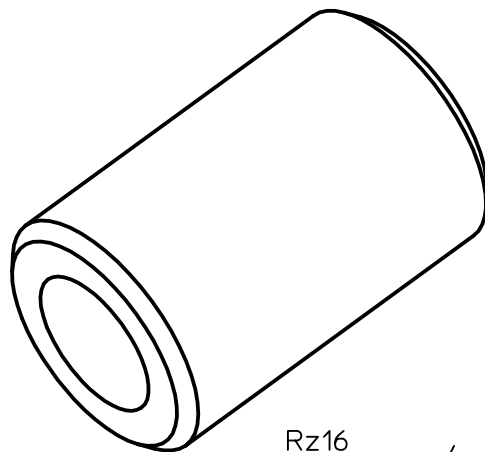
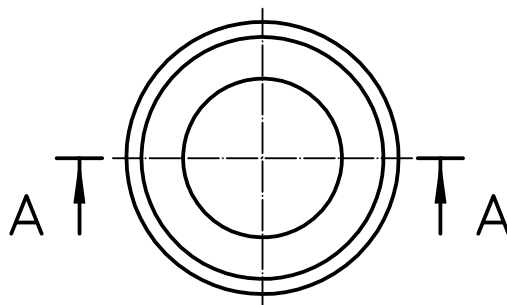
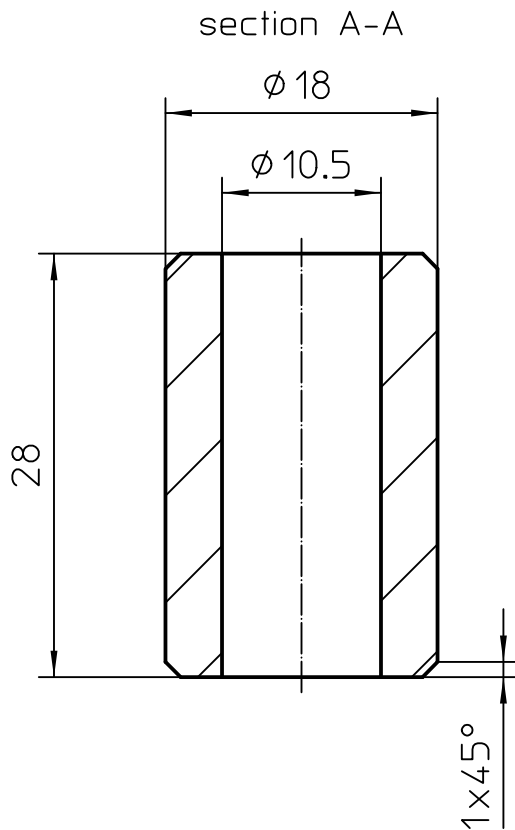

$\begin{matrix} -0.4 \\ -0.2 \end{matrix}$       $\begin{matrix} +0.5 \\ +0.3 \end{matrix}$   
 Workpiece edges ÖNORM ISO 13715

Allgemeintoleranzen ISO 22081

lineare Größenmaße:  $\pm 0.1$

Winkelgrößenmaße:  $\pm 1^\circ$

Rz16



1	6	Distanzbuchse $\varnothing 10,5$	Messing		
Menge	Pos.-Nr.	Benennung	Material	Rohmaß	Beschreibung

## LEHRLINGSWETTBEWERB

Maßstab

1:1

Schnittwerkzeug

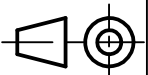

Variante 2



Beruf: M2

Zeichnungs- Nr.: M2-2g\_V1.0\_2024

Diese Zeichnung ist Eigentum der WIRTSCHAFTSKAMMER - Oberösterreich