

Gefeilte Flächen dürfen nicht vorgefräst werden!

±0.1

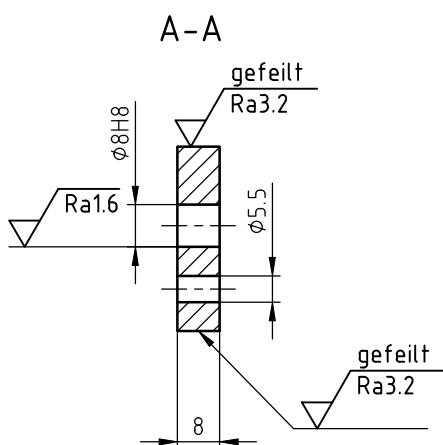
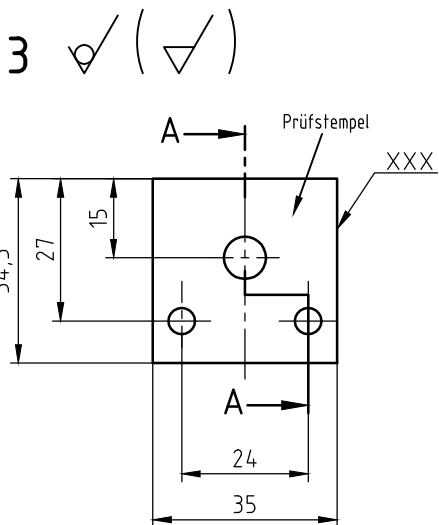
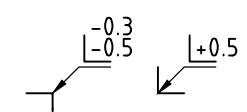
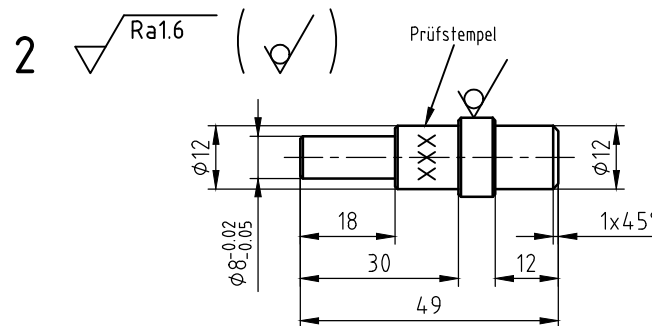
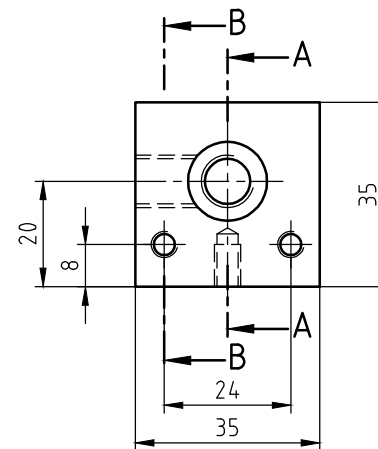
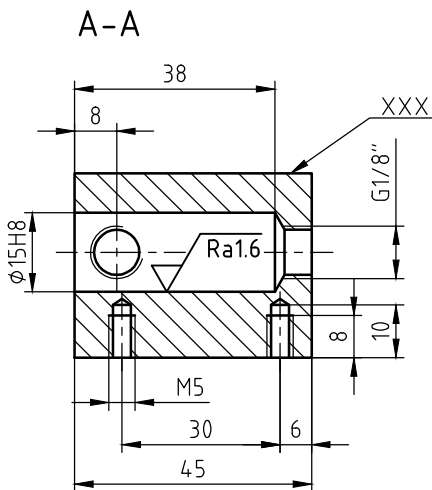
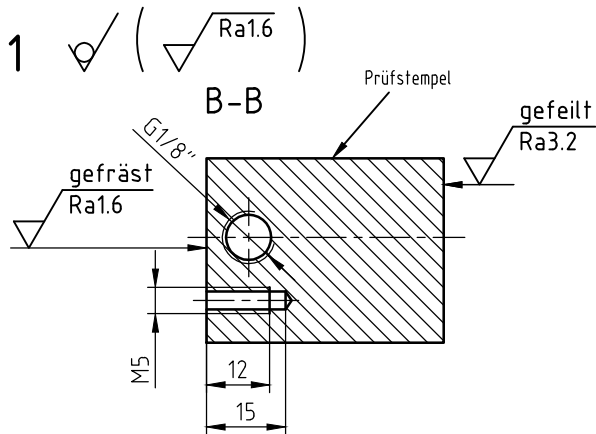

1	Platte	3	C45K	35x8x36	
1	Kolben	2	C35K/1.0715	∅15x51	
1	Zylinder	1	9SMn36 / 1.0736	35x35x47	
Stück	Benennung	Teil	Norm - Nr. / Werkstoff	Rohmaße	Bemerkung

Kennnummer: XXX Arbeitszeit: 6 Stunden

LEHRLINGSWETTBEWERB

Maßstab
1:1,43

Spannvorrichtung

**WIRTSCHAFTSKAMMER OBERÖSTERREICH
DIE INDUSTRIE**

Beruf: M5 Format: A4 Zeichnungs- Nr.: M5-3E-V1.6

Diese Zeichnung ist Eigentum der WIRTSCHAFTSKAMMER - Oberösterreich