

Lehrlingswettbewerb der Sparte Industrie NÖ

Kategorie 6: - Mechatronik





 - Automatisierungs- und Prozessleittechnik

Bearbeitung: - Mechanische Fertigung eines Werkstückes













 - mechatronische Aufgabe (Elektropneumatik,



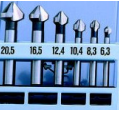

 Elektrotechnik, SPS-Programmierung)

Messmittel

Messschieber 150 mm	
Universalwinkelmesser	
Radiuslehre R1 - R15	
Rollmaßband 2 m	

Werkzeuge

Körner	
Reißnadel	
Handbügelsäge mit Ersatzblättern	
Bastard-Feilen (Schrupp-Feile) ca. 150 - 250 mm Schlichtfeile ca. 150 - 250 mm	 <p>Flachstumpfeile Dreikantfeile Vierkantfeile</p>
Schlüsselfeilen	
Feilenbürste	
Schraubstock Schutzbacken	
Putztücher	
Spiralbohrer 1,0 mm - 10,0 mm x 0,1 mm steigend	
Kegel- und Entgratsenker-Satz 90° DIN 335-C	
Flachsener - Satz M 3 - M 10	
Handgewindebohrer-Satz M 6 Windeisen	
Schraubendreher - Satz Abtrieb: Schlitz, Phillips	

Seitenschneider Abisolierzange Aderendhülsenpresszange	
Schlosserhammer 300g	
Schlagzahlen - Satz 3 oder 5 mm 0 - 9 Normalschrift	
Gewindeschneidstift oder Schmierstift	
Taschenrechner Schreibutensilien Lineale	

Persönliche Schutzausrüstung

Schutzbrille Sicherheitsschuhe Arbeitskleidung, bei langen Haaren: Haarnetz oder Kappe tragen	
--	---

Am Prüfungsort WIFI TAZ vorhanden:

- Parallelschraubstock 100 - 150 mm Backenbereite
- Bohrmaschine 0 - 13 mm u. MK1, MK2
- Anreißplatte mit Parallelreißer und Anreißprisma